

Color Blast

Montbel
made in Italy

È una questione di colore.

È una questione di sartorialità.

Crediamo nella cultura dell'autenticità
e nella qualità. Il nostro prodotto si unisce
al vostro progetto e diventa
il testimone di unicità e personalità.

It's a matter of color.

It is a matter of tailoring.

We believe in the culture of authenticity
and quality. Our product joins your project
and becomes the witness
of uniqueness and personality.

Manuela Montana

Index

004	60 Years of passion
006	Wood & Colors
008	Authentic taylor made
010	Sustainability at heart
012	Star system signatures
014	Chair for charity
016	An award-winning armchair
018	Project highlights
020	Life in technicolors
022	Tropical Aquarium
024	Orange & Tangerine

026	Maja
038	Sofia
058	Tablet
076	Wings
092	Yarda
106	Flor
118	Rose
168	Danielle
198	Lily
218	Niky
234	Light
250	Offset
260	Garbo
272	Rivoli
286	Sayo
298	Chanel
328	Star
342	Euforia Air
358	Euforia System
380	Cushions
382	Diadema
392	Line
402	Cono
414	Flen

LEGENDA DISEGNI TECNICI

L. larghezza	H.s. altezza seduta
P. profondità	H.b. altezza braccioli
H. altezza	

TECHNICAL DRAWINGS KEY

W. width	S.h. seat height
D. depth	A.h. arm height
H. height	

60 Years of passion



Ci occupiamo da oltre mezzo secolo di un oggetto quotidiano usato in tutto il mondo, soprattutto mai banale: la sedia.

La nostra azienda è stata creata nel 1959 da Silvano Montina che ha da subito imposto i principi che rappresentano tuttora l'impronta della nostra attività: qualità dei materiali, cura del prodotto in ogni dettaglio ed attenzione alle esigenze del cliente.

Siamo cresciuti con il passare degli anni con i nostri prodotti, le persone e una storia familiare straordinaria. È proprio grazie alla continuità generazionale che siamo riusciti, a partire dagli anni '90, a proporre le nostre collezioni al mercato nazionale ed internazionale consolidando la reputazione del nostro brand.

Le nostre creazioni parlano di funzionalità, ma anche di design, di comfort ma anche di resistenza a severi test per soddisfare i nostri clienti nel settore contract e residenziale.

Ogni anno con l'introduzione di nuovi modelli vogliamo confermare un'evoluzione continua, che ha radici nel passato, si afferma nel presente ed è proiettata al futuro. Sposando tecnica ed estetica, contribuiamo a rendere più belle, razionali ed accoglienti le aree dell'abitare, dell'ospitalità e dei luoghi di lavoro.

Proponiamo la nostra anima italiana esportandola con successo in tutto il mondo ed esclusivamente 100% Made in Italy.



“Siamo cresciuti con i nostri prodotti, le persone e una storia familiare straordinaria”

“WE GREW WITH OUR PRODUCTS, PEOPLE AND AN EXTRAORDINARY FAMILY STORY”

For more than half a century we have dealt with an object of daily use found throughout the world, above all never banal: chairs.

Silvano Montina, having established our company in 1959, at once laid down the principles representing our activity's footprint to date: quality of materials, care for each product detail and heeding what our customers require.

As years went by, we grew with our products, people and an extraordinary family story. It is just thanks to our generational continuity that we have succeeded, ever since the 1990s, in proposing our collections to the domestic and international markets, while consolidating the reputation of our brand.

Our creations are about functionality, yet also design, comfort and resistance to severe tests, in order to satisfy our customers in both the contract and residential sectors.

Every year, when introducing new models, we wish to confirm a continual evolution, rooted in the past, affirming itself in the present and projected into the future. By combining technique and aesthetics, we contribute to making workplaces, the areas where we live and receive our guests more attractive, rational and welcoming.

We propose our Italian soul, exclusively 100% “Made-in-Italy”, by exporting it successfully all over the world.

Wood core & colors



La tradizione e la cultura artigianale sono la nostra arte. Mettiamo l'uomo al centro di ogni progetto, dalla ricerca alla realizzazione.

Sviluppiamo prodotti che partono dalla lavorazione del massello. I nostri manufatti sono delle piccole architetture colorate che si impreziosiscono con materiali all'avanguardia sapientemente confezionati.

La mano dell'uomo trasforma la materia in prodotto, realizzato a regola d'arte con un ciclo di lavorazione totalmente interno conservando un esclusivo percorso di qualità.

Tradition and the culture of craftsmanship represent our art. We place the human being at the centre of each project, from research to realization.

We develop products which begin from processing hardwood. Our artifacts are small, coloured architectures that become precious with expertly manufactured vanguard materials.

Man's hand transforms matter into an article, made according to the rules of art, in an entirely in-house processing cycle, upholding an exclusive quality path.

Ogni prodotto è realizzato a regola d'arte grazie a un ciclo di produzione incentrato sulla qualità.



EACH ITEM IS STATE-OF-THE-ART MADE, THROUGH A PRODUCTION CYCLE CENTRING ON QUALITY.

Authentic taylor made

Il ciclo interno di confezione veste le strutture come abiti su misura. Il processo sartoriale ci contraddistingue per la cura del dettaglio e la scelta dei materiali, tessuti, pelli ed ecopelli.

La cultura di progetto diventa una filosofia di prodotto "pret a porter", fatta di manualità, esperienza e sensorialità.

Our internal manufacturing cycle dresses our structures, as if they were tailored clothing made to fit perfectly.

A tailor's method actually distinguishes us, due to both our care for details and how we choose materials, fabrics, leather, & ecoleathers.

Our project culture becomes a ready-to-wear product philosophy, featuring manual labour, experience and sensoriality.

La cultura di progetto diventa una filosofia di prodotto pret a porter.

THE PROJECT CULTURE BECOMES A READY-
TO-WEAR PRODUCT PHILOSOPHY.



Sustainable at heart

Consideriamo la sostenibilità come parte integrante della progettazione. Promuoviamo un design intelligente, che nasce nella cultura dell'autenticità e della sartorialità e cresce, nel corso dei decenni, di generazione in generazione. Siamo sempre alla ricerca di soluzioni ottimali e ci sforziamo di sviluppare continuamente i nostri prodotti non solo in termini di forma estetica, ma anche di materiali.

Sustainability is an integral part of our design process. We believe in intelligent, authentic and bespoke design which evolves, over the decades, from one generation to the next. We strive to deliver only the best solutions and constantly improve our products, enhancing their aesthetic appeal and sourcing new and better materials.



The Italian Concept

Scopri di più su come Montbel si impegna ad essere sostenibile.
Find out more about Montbel's commitment towards sustainability.



Star system Signatures



Tony Servillo Alessandro Gassmann Spike Lee Violante Placido Tim Roth Annabel Shooley Elettra Mallaby Matteo Garrone Vanessa Redgrave William Dafoe

Da diversi anni sosteniamo Ai.Bi., l'associazione amici dei bambini, doniamo le nostre sedute nella versione autografata dalle celebrità ospiti al Festival del Cinema di Venezia, in occasione della Mostra Internazionale d'Arte Cinematografica di Venezia.

Le sedute vengono battute all'asta durante la cena di gala organizzata da Ai. Bi., Il Bello che fa bene. Obiettivo dell'evento oltre a sensibilizzare sul tema, è raccogliere fondi a sostegno della missione di Ai.Bi., che da oltre trent'anni lavora ogni giorno accanto ai bambini abbandonati ed in grave difficoltà familiare, per garantire loro il diritto ad essere figli.

Questa è una collaborazione che inorgoglisce l'azienda, da sempre attenta al sociale.

For several years now, Ai.Bi., the children's friends association, has been supported by Montbel; our seating is donated in its version autographed by the celebrities who are guests at Venice's Film Festival, on the occasion of Venice's International Cinematography Art Show.

The seating gets auctioned off during a gala dinner, arranged by "Il Bello che fa bene" (=the Beautiful that does well). Besides increasing awareness on the theme, the event's objective is to raise funds supporting the mission at Ai.Bi.'s, who, day in day out, for over thirty years, have been working alongside children, abandoned and with serious family difficulties, in order to ensure them the right to be real sons and daughters.

Such a collaboration makes us proud as a company, having always carefully followed social initiatives and issues.

Chair for Charity

Montbel da sempre sensibile ai temi sociali, ha deciso di sostenere l'Associazione Edela che da anni si prende cura degli orfani di femminicidio, donando parte del ricavato dalla vendita della nuova seduta Sofia appositamente progettata dai designer Edi e Paolo Ciani.

Sofia traduce un progetto sociale importante che lega l'azienda a questa Associazione contribuendo ad assicurare un futuro migliore a bambini e ragazzi invisibili su cui Edela veglia come una mamma, donna angelo per l'eternità.

L'obiettivo è che sempre più persone venendo a conoscenza del progetto decidano di unirsi a noi regalando una seconda possibilità a questi bambini.

Il ricavato consentirà di continuare ad offrire aiuto psicologico professionale e affiancamento nella formazione, attraverso il sostegno delle spese per tasse scolastiche, libri e doposcuola, spese mediche e alimentari, sport e formazione extrascolastica regalando a questi ragazzi una nuova possibilità.

Montbel has always been sensitive to social issues, we have therefore decided to support the Edela Association which, for many years has taken care of orphans of femicide. Montbel will be donating to Edela a proportion of the proceeds from the sale of their new Sofia chair which has been specially designed by the designers Edi and Paolo Ciani.

Sofia translates an important social project that binds the company to this association, helping to ensure a better future for the invisible children and young people Edela watches over like a mother, a female eternal angel.

The goal is that more and more people will learn about the project and decide to join us in giving these children a second chance.

The proceeds will make it possible to continue to offer professional psychological help, coaching in education, support for school fees, books and after-school care, medical and food expenses, sports and extracurricular training, giving these children a new chance.

Montbel
made in Italy

Edela
ASSOCIAZIONE A SOSTEGNO DEGLI ORFANI DI FEMMINICIDIO



An award-winning armchair

Con la sua elegante palette di colori, Tablet è una poltroncina dalla personalità vivace e accattivante.

La sua originalità, ricerca e innovazione le hanno valso prestigiosi premi tra i quali ricordiamo il **"Best of Year Awards 2022"** nella categoria Contract Lounge, **"HiP Award 2022"** per la miglior seduta nella categoria Hospitality al NeoCon di Chicago e il premio **"The Best Seating category"** alla product design competition BDNY 2022.

Le sue linee avvolgenti danno vita a un profilo contemporaneo, capace di combinare estetica e comfort in un'unica forma, semplice e compatta. Personalizzabile in base alle richieste del cliente, Tablet è adatta a essere integrata in qualsiasi contesto, dalle abitazioni di interior design, sino al contract e alle hotellerie.

La compagnia Delta Airlines ha selezionato la poltroncina Tablet per arredare le sue lounge aeroportuali.

With its elegant colour palette, Tablet is a small armchair with a lively and appealing personality.

Its originality, research and innovation have earned it prestigious awards, including: **"Best of Year Awards 2022"** in the Contract Lounge Seating category, the **"HiP Award 2022"** at NeoCon Chicago for best seating in the Hospitality category, and **"The Best Seating category"** during the product design competition BDNY 2022.

The contemporary profile of its wraparound design combines aesthetics with comfort in a single, simple and compact shape. Tablet can be customized to client requirements and blends in perfectly with any setting, whether the interior design of a private home, the contract sector or the hotel industry.

Delta Airlines chose the Tablet small armchair to decorate its lounges.

Design by Daniele Lo Scalzo Moscheri, 2022

Winner of:

NeoCon® BD|NY

INTERIOR
DESIGN

HiP
HONORING INDUSTRY PEOPLE & PRODUCTS



Project Highlights

ACQUA DI PARMA

Athens
London
Miami
Milan
Paris
Rome
Venice

BACARDI

HEAD QUARTER
Coral Gables USA

BVLGARI HOTELS

Dubai
London
Moscow
Tokyo

CARNIVAL

Azura
Conquist
Horizon
Triumph
Victory
Vista

DELTA SKYCLUB LOUNGES

USA

FALKENSTEINER

Family Resort Lido Ehrenburg
BZ Italy
Hotel & Spa Jesolo Italy
Hotel & Residence Punta
Skala Croatia

GIANFRANCO FERRÈ RESTAURANT

Dubai

GRAND FERDINAND-HOTEL AM RING

Vienna, Austria

HARROD'S AVIATION LOUNGE

London

HYATT HOTELS

Houston
Hamburg
San Francisco

HOTELS GROUPE BARRIERE

Cannes
Courchevelle
Deauville
La Baule

HOTEL MELIÀ

Frankfurt City Frankfurt
Germany
Melià Valencia Spain
Melia White House London GB

HOTEL SANTO SPIRITO

Bergamo

HOTUSA

Aurea Ana Palace Budapest,
Hungary
Aurea Palacio de Correos
Logromo, Spain
Eurostar Gran Via Granada,
Spain
Eurostar Universa Lisboa,
Portugal

MANDARIN ORIENTAL HOTEL DU RHONE

Switzerland

MARRIOTT HOTELS

Belgrade
Berlin
Greensboro
Milton Keynes
Hong Kong
Vienna

MERCURE HOTELS

Frankfurt
Graz
La Baulle
Orleans
Salzburg
Vienna

MOTEL ONE DRESDEN AM ZWINGER

Germany

MOTEL ONE KÖLN MEDIAPARK

Germany

PARK HOTEL VITZNAU

Vitznau CH

PRINCESS HOTELS & RESORTS

Grand Bavaro Princess Rep.
Domenicana

PULLMANN HOTEL STUTTGART

Germany

RADISSON BLU HOTELS

Cologne
Fargo
Helsinki
Ikeja-Lagos
Oslo
Stockholm
Turku
Vienna

RIST. LE LAMPARE AL FORTINO

Trani, Italy

ROYAL CARIBBEAN

Azamara Quest
Enchantment of the Sea
Harmony of the Seas
Oasis of the Seas
Symphony of the Seas

SHERATON HOTELS

Amsterdam
Algeri
Chicago O'Hare
Frankfurt
Kagoshima
Munich
Tampa (FL)
Tel Aviv
Toronto

HILTON HOTELS

Airrail Frankfurt
Berlin
Charles de Gaulle (Paris)
Glasgow
London
Munich
Tampa (FL)
Washington
Zurich

STEIGENBERGER HOTELS

Kaprun
Bad

SWISSOTEL

Sydney, Australia

WYNN RESORTS

Las Vegas USA
Maccou Hong Kong

Le nostre collezioni interpretano progetti in tutto il mondo. L'esperienza accumulata nel corso dei decenni con progetti nazionali ed internazionali ha reso Montbel una realtà riconosciuta nel mondo del Contract. Il prodotto si evolve in infiniti confini applicativi, con linguaggi internazionali e personali, rappresentando l'Italian Design in tutto il mondo.

Our collections interpret projects from all over the world. The experience thus accumulated over decades, with national and international projects, has made Montbel - a reality acknowledged throughout the world of Contract. Our product evolves within unending applicative borderlines, expressing itself in international and personal languages, representing Italian Design globally.



Life in technicolors

“Per me i colori sono degli esseri viventi, degli individui molto evoluti che si integrano con noi e con tutto il mondo. I colori sono i veri abitanti dello spazio.”

(Yves Klein)



“FOR ME, COLOURS ARE LIVING BEINGS, VERY MUCH EVOLVED INDIVIDUALS THAT BLEND WITH US AND THE WHOLE WORLD. COLOURS ARE THE AUTHENTIC DENIZENS OF SPACE.”

Tropical aquarium

"Ogni colore che noi vediamo
nasce dall'influenza del suo vicino."

(Claude Monet)



"EVERY COLOUR THAT WE SEE IS GENERATED
BY ITS NEIGHBOUR'S SWAY."

Orange & Tangerine

“Il disegno e il colore non sono affatto distinti.
Mano che si dipinge, si disegna. Più il colore diventa
armonioso più il disegno si fa preciso”

(Paul Cézanne)



“DESIGN AND COLOUR ARE FAR FROM BEING DISTINCT.
A HAND WHICH PAINTS ITSELF DRAWS ITSELF.
THE MORE A COLOUR GETS HARMONIOUS,
THE MORE PRECISE THE DESIGN BECOMES”

Maja

By Sven Dogs Studio

Una seduta elegante dalle cuciture di grande impatto, Maja è pensata per regalare il massimo comfort grazie ai tre rigonfiamenti che ne caratterizzano l'aspetto rendendola unica nel suo genere.



Watch the video.

A SEATING ITEM WITH SEAMS OF GREAT IMPACT, MAJA HAS BEEN DEVISED TO PROVIDE UTMOST COMFORTABLENESS, THANKS TO THE THREE BULGES CHARACTERIZING ITS ASPECT AND MAKING IT UNIQUE IN ITS KIND.



05731



05732



05735





Morbida e leggera, e al tempo stesso solida e sostanziosa. Maja è la nuova poltroncina Montbel che celebra il confort della bellezza.

La soffice imbottitura dello schienale in velluto è esaltata dalle linee arrotondate dei tre rigonfiamenti disegnati dalle cuciture, capaci di offrire un riparo accogliente dove prendersi una pausa.

Una silhouette sinuosa e rasserenante progettata per mettere al centro il benessere del corpo e della mente. Maja è disponibile con base quattro gambe in legno, o slitta.

Soft and light, yet robust: Maja is the new Montbel armchair that celebrates the comfort of beauty.

The curved, relaxing silhouette has been designed with a strong focus on the well-being of the body and mind.

The rounded lines of the three bulges created by the stitching enhance the backrest's soft velvet upholstery, offering a cosy and generous place to rest. Maja is available with a four-leg wooden sledge or castor base.

“Volevo una sedia morbida che fosse diversa, più comoda delle altre che facesse sognare chi ci si siede”.

“I WANTED A SOFT SEAT WHICH WOULD BE DIFFERENT, COSIER THAN THE OTHERS, THAT WOULD MAKE THE SITTER DREAM.”

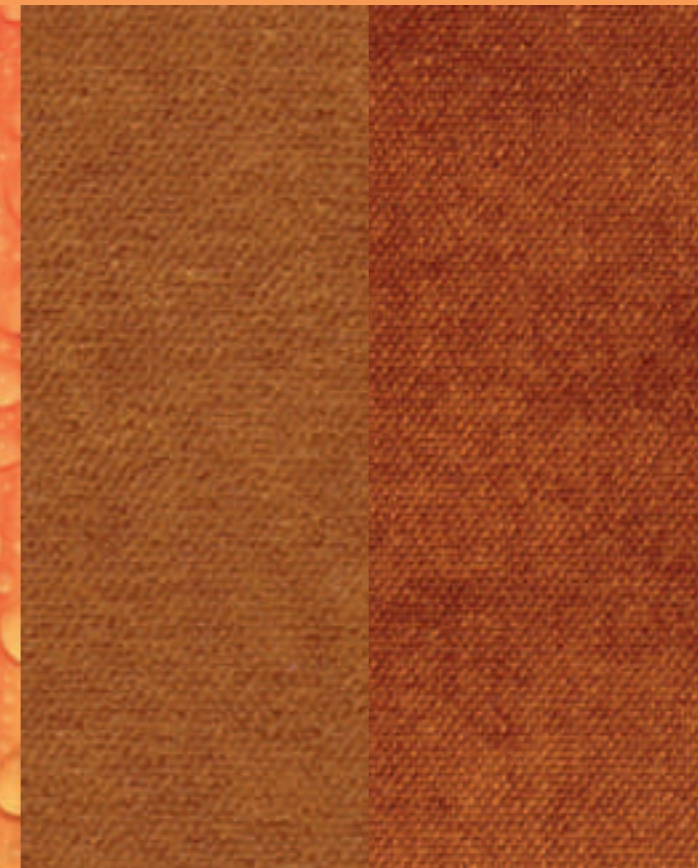

Technical sheet



05731

L.69cm P.62 cm H.77cm
H.s.48cm

W.27,2 D.24,4
H.30,3 S.h.18,9



05735

L.69cm P.62 cm H.77cm
H.s.48cm

W.27,2 D.24,4
H.30,3 S.h.18,9



05732

L.69cm P.62 cm H.77cm
H.s.48cm

W.27,2 D.24,4
H.30,3 S.h.18,9



05733

L.69cm P.62 cm H.77cm
H.s.48cm

W.27,2 D.24,4
H.30,3 S.h.18,9



Sofia

By Edi & Paolo Ciani

Le linee sinuose e delicate di Sofia danno vita a un design accogliente e intimo che caratterizza con sobria determinazione sia spazi *contract* che *home living*.



Watch the video.

SOFIA'S SINUOUS, DELICATE CURVES BRING LIFE TO A WELCOMING, INTIMATE DESIGN, DISTINGUISHING WITH SOBER DETERMINATION THE SPACES OF BOTH THE CONTRACT AND HOME-LIVING AREAS.





MONTBEL . 044

SOFIA . 045



MONTBEL . 046



SOFIA . 047



Le sedute Sofia presentano forme generose ed avvolgenti. Sono caratterizzate da linee sinuose e delicate che generano superfici modellate appositamente per accogliere il corpo come in un dolce abbraccio, dando vita a uno spazio di elegante e confortevole intimità e caratterizzando con sobria determinazione sia spazi *contract* che *home living*.

La particolarità dell'effetto "doppio schienale" che contraddistingue le sedute della collezione Sofia ne valorizza le capacità comunicative, suscitando una connessione emotiva con il fruitore.

L'uso del poliuretano espanso, unito alla scelta dei materiali di prima qualità ed il loro eccellente livello di lavorazione, garantiscono ai prodotti una bellezza che rimane immutata nel tempo.

La doppia proposta di basamento, in legno e in metallo, in combinazione con l'ampia scelta di rivestimenti e finiture a disposizione, la rendono facilmente accostabile sia ad arredi dallo stile classico moderno, che a location dallo spirito contemporaneo e *Urban-Chic*.

The Sofia seating items present generous, enrapturing shapes. They feature sinuous, delicate lines generating surfaces modelled purposely to welcome the body as if in a sweet embrace, producing a space of smart, comfy intimacy, and characterising both *contract zone* and *home-living* spaces with sober determination.

The peculiarity of the "double backrest" effect distinguishing the Sofia seating collection increases their communication worth, arousing an emotional link with the user.

The employment of polyurethane foam together with the choice of high quality materials and their excellent level of processing, guarantee said products a beauty to remain unchanged over time.

The double base proposal, wooden and metal, matched with the wide choice of coverings and finishes at disposal, make it easily approachable to either classic modern style furnishings, or contemporary spirit and *urban-chic* locations.

Linee sinuose e delicate generano superfici pensate per accogliere il corpo in un dolce abbraccio.

SINUOUS, DELICATE LINES
GENERATE SURFACES
CONCOCTED TO WELCOME THE
BODY IN A SWEET EMBRACE.

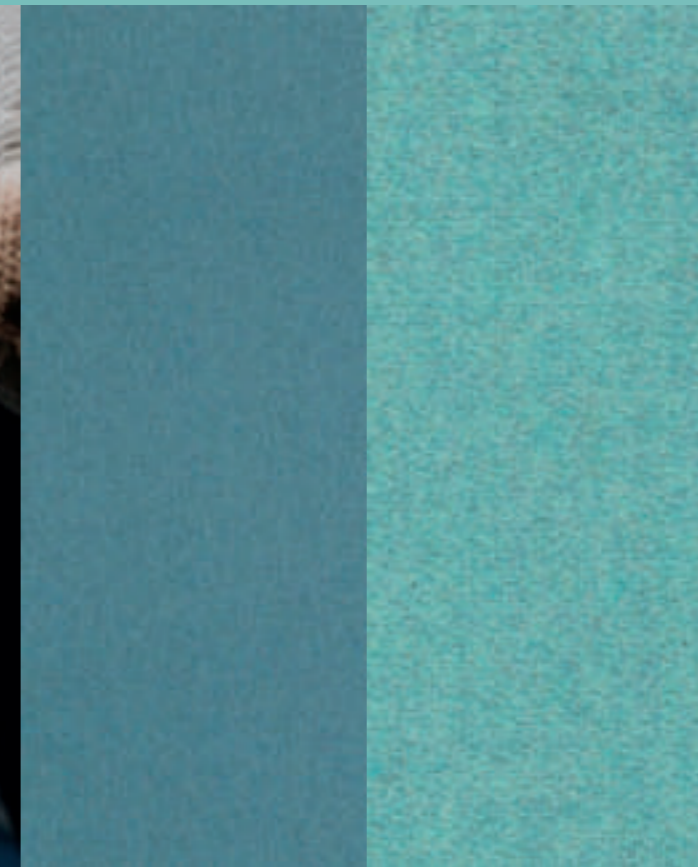





MONTBEL . 054



SOFIA . 055



Technical sheet



05631

L.63cm P.68 cm H.89cm
H.s.48cm

W.24,8 D.26,6
H.35 S.h.18,9



05635

L.63cm P.68 cm H.91cm
H.s.48.5cm

W.24,8 D.26,8
H.35,8 S.h.19,1



05636

L.63cm P.68 cm H.91cm
H.s.48,5cm

W.24,8 D.26,8
H.35,8 S.h.19,1



05641

L.73cm P.73 cm H.92cm
H.s.45cm

W.28,7 D.28,7
H.36,2 S.h.17,7



05645

L.73cm P.73 cm H.92cm
H.s.45cm

W.28,7 D.28,7
H.36,2 S.h.17,7

Tablet

By Daniele Lo Scalzo Moscheri

Nel cerchio risiede l'estetica della perfezione che in Tablet si trasforma in tridimensionalità. Il cilindro e lo schienale avvolgente contraddistinguono una seduta formalmente versatile a cui si aggiungono i pouf ed il divano con due versioni di schienale.



Watch the video.

IN THE CIRCLE RESIDES THE AESTHETIC OF PERFECTION, WHICH IN TABLET CHANGES IN TO THE TRIDIMENSIONAL. THE CYLINDER AND THE ENRAPTURING BACKREST DISTINGUISH A FORMALLY VERSATILE ITEM OF SEATING TO WHICH ARE ADDED POUFS AND THE SOFA, WITH TWO BACKREST VERSIONS.





Il cerchio è una linea retta che torna al suo punto di partenza.

La ricerca di un segno nitido e preciso determina un'outline del prodotto con una ricerca estrema di proporzione.

Tablet è una collezione semplice in cui il dettaglio prende forza e diventa protagonista di una estetica senza tempo ma soprattutto progettualmente versatile.

A circle is a straight line which returns to its starting point.

The quest for a clean, precise mark determines a product's outline through an extreme search for proportion.

Tablet is a collection where the detail gains strength and becomes protagonist of a timeless yet - above all - projectually versatile aesthetic.

Il dettaglio prende forza traducendosi in una estetica senza tempo.

THE DETAIL GAINS STRENGTH MORPHING INTO A TIMELESS AESTHETIC.







MONTBEL . 070



TABLET . 071





05251



05276



05253

Technical sheet



05231-05232
L.64cm P.64 cm H.77cm
H.s.48cm
W.25 1/5" D.25 1/5"
H.30 1/3" S.h.18 3/4



05234-05235
L.66cm P.60 cm H.76.5cm
H.s.48cm
W.26 D.23,6
H.30,1 S.h.18,9



05233
L.66cm P.60 cm H.76.5cm
H.s.48cm
W.26 D.23,6
H.30,1 S.h.18,9



05271-05272
L.57cm P.57 cm H.48cm
H.s.48cm
W.22,4 D.22,4
H.18,9 S.h.18,9



05274-05275
L.57cm P.57 cm H.48cm
H.s.48cm
W.22,4 D.22,4
H.18,9 S.h.18,9



05273
L.57cm P.57 cm H.48cm
H.s.48cm
W.22,4 D.22,4
H.18,9 S.h.18,9



05251-05252
L.166cm P.60 cm H.77cm
H.s.48cm
W.65,4 D.23,6
H.30,3 S.h.18,9



05253-05254
L.166cm P.60 cm H.90cm
H.s.48cm
W.65,4 D.23,6
H.35,4 S.h.18,9



05276-05277
L.160cm P.59 cm H.48cm
H.s.48cm
W.63 D.23.2
H.18.9 S.h.18.9

Bars and casual dining

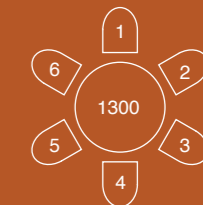
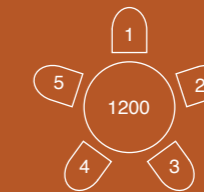
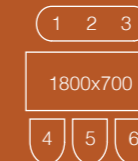
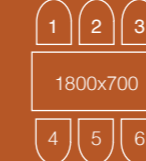
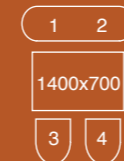
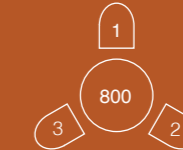
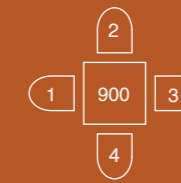

Formal dining

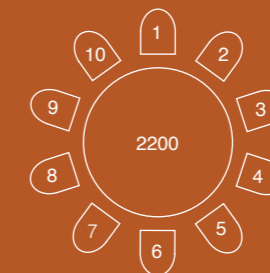
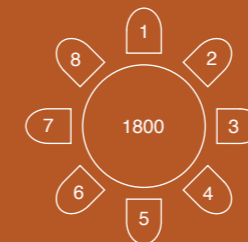
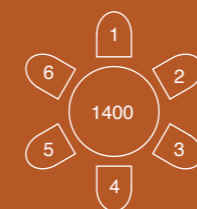
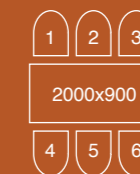
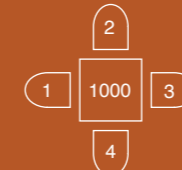

Wings

By Edi & Paolo Ciani

Sedute dalle forme importanti e dai volumi generosi trovano il loro elemento distintivo nell'originale schienale dove si incontrano i due elementi laterali.



Watch the video.

SEATING WITH IMPORTANT SHAPES AND GENEROUS VOLUMES FIND THEIR DISTINCTIVE ELEMENT IN THE ORIGINAL BACKREST WHERE THE TWO SIDE ELEMENTS COME TOGETHER.







La collezione *Wings* si contraddistingue per l'originale schienale con le "ali" che, pur essendo costruttivamente un elemento unico, grazie a particolari accorgimenti, esteticamente risulta suddiviso in tre parti.

I due elementi laterali abbracciano con charme la parte centrale, evocando sensazioni di leggerezza, accoglienza e comfort.

Le ali possono essere personalizzate mediante la scelta di un rivestimento differente, in contrasto o ton sur ton, così da enfatizzare ulteriormente il concept esclusivo e fortemente riconoscibile di questa collezione.

Il modello è realizzato in poliuretano espanso, materiale che assicura costantemente nel tempo morbidezza e indeformabilità.

Il fusto in legno massello è caratterizzato da particolari lavorazioni e dettagli costruttivi ricercati che consentono ai modelli *Wings* di soddisfare anche la clientela più esigente in termini di durata e resistenza dei prodotti.

Our *Wings* collection features a unique backrest with "wings": though it is a single element from a constructional viewpoint, aesthetically it appears - by means of special expedients - to consist of three parts.

The two side elements charmingly embrace the central part, evoking sensations of lightness, warmth, and comfort.

The wings may be customised by choosing alternative cladding - contrasting, or tone over tone - so as to further underline the exclusive, powerfully recognizable concept of this collection.

The model is made of polyurethane foam, a material ensuring softness and shape retention constantly, as time goes by.

The solid wood frame is the outcome of special processing systems and construction details, allowing for our *Wings* models to meet the requirements of even the most demanding clientele, in terms of product durability and endurance.

Leggerezza accoglienza
e comfort in un tratto.

LIGHTNESS, WARMTH AND COMFORT,
IN A SINGLE STROKE.

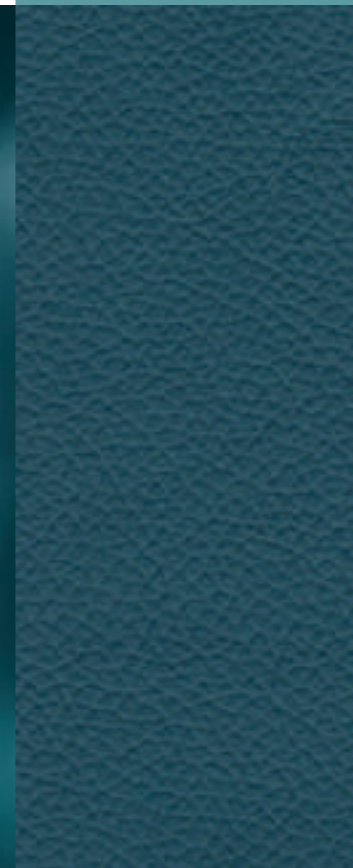

MONTBEL . 086



05141

WINGS . 087





Technical sheet



05111
L.51cm P.61 cm H.87cm
H.s.48cm
W.20,1" D.24"
H.34,3" S.h.18,9"



05131
L.62cm P.64 cm H.87cm
H.s.48cm
W.20,1" D.24"
H.34,3" S.h.18,9"



05141
L.75,5cm P.80 cm H.89,5cm
H.s.47,5cm
W.29,7" D.31,1"
H.35,2" S.h.18,7"



05181
L.47cm P.54 cm H.110cm
H.s.79cm
W.18,5" D.21,3"
H.43,3" S.h.31,1"

Bars and casual dining

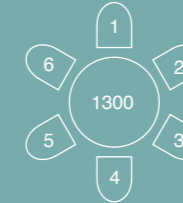
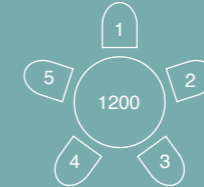
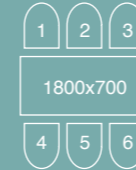
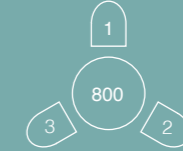
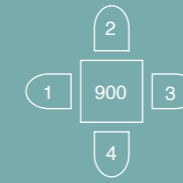

Formal dining

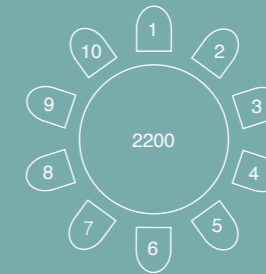
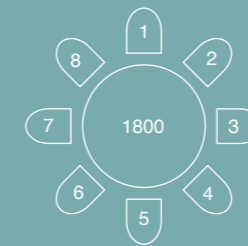
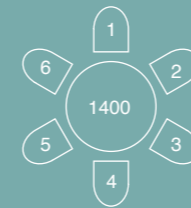
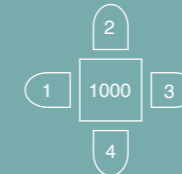



Yarda

By Yonoh

Una seduta che avvolge incoraggiando
movimenti naturali.



Watch the video.

A SEAT THAT ENVELOPS AND ENCOURAGES
NATURAL MOVMENTS.



L'hospitality si sta avvicinando al settore della casa ed è per questo che i prodotti sviluppati per hotel e ristoranti devono evocare la stessa atmosfera.

Il grande schienale che abbraccia come un cappotto consente di muoversi con naturalezza e riflette la cura per i dettagli e l'attenzione all'ergonomia che sono stati posti nella realizzazione di Yarda.

Abbiamo voluto realizzare una struttura solida con dettagli che dimostrassero le qualità del legno ispirandoci agli innesti che sono diventati il carattere distintivo di Yarda.

Hospitality is coming closer to the home sector and that's why the products that are developed for hotels and restaurants should evoke the same atmosphere.

The large backrest that grabs like coat allows natural movements and reflects the attention to details and ergonomics that have been emphasised in Yarda design.

We wanted to make a solid structure with details that would demonstrate the virtues of wood by looking at grafts which have become Yarda distinctive's feature.

“L'arredo dell'hospitality deve richiamare l'atmosfera della casa”

“THE HOSPITALITY'S INTERIOR SHOULD EVOKE THE HOUSE ATMOPHERE”

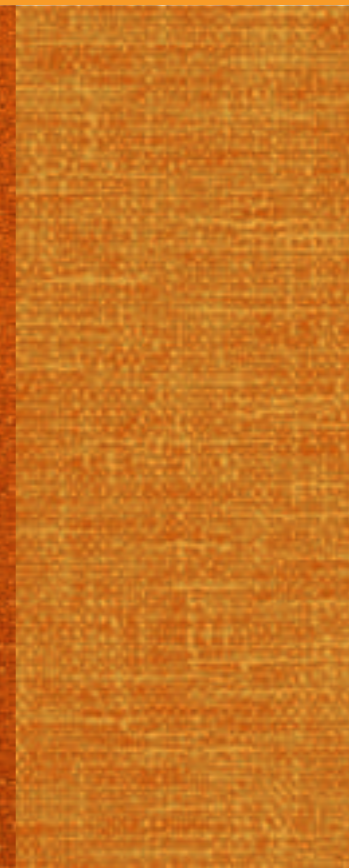



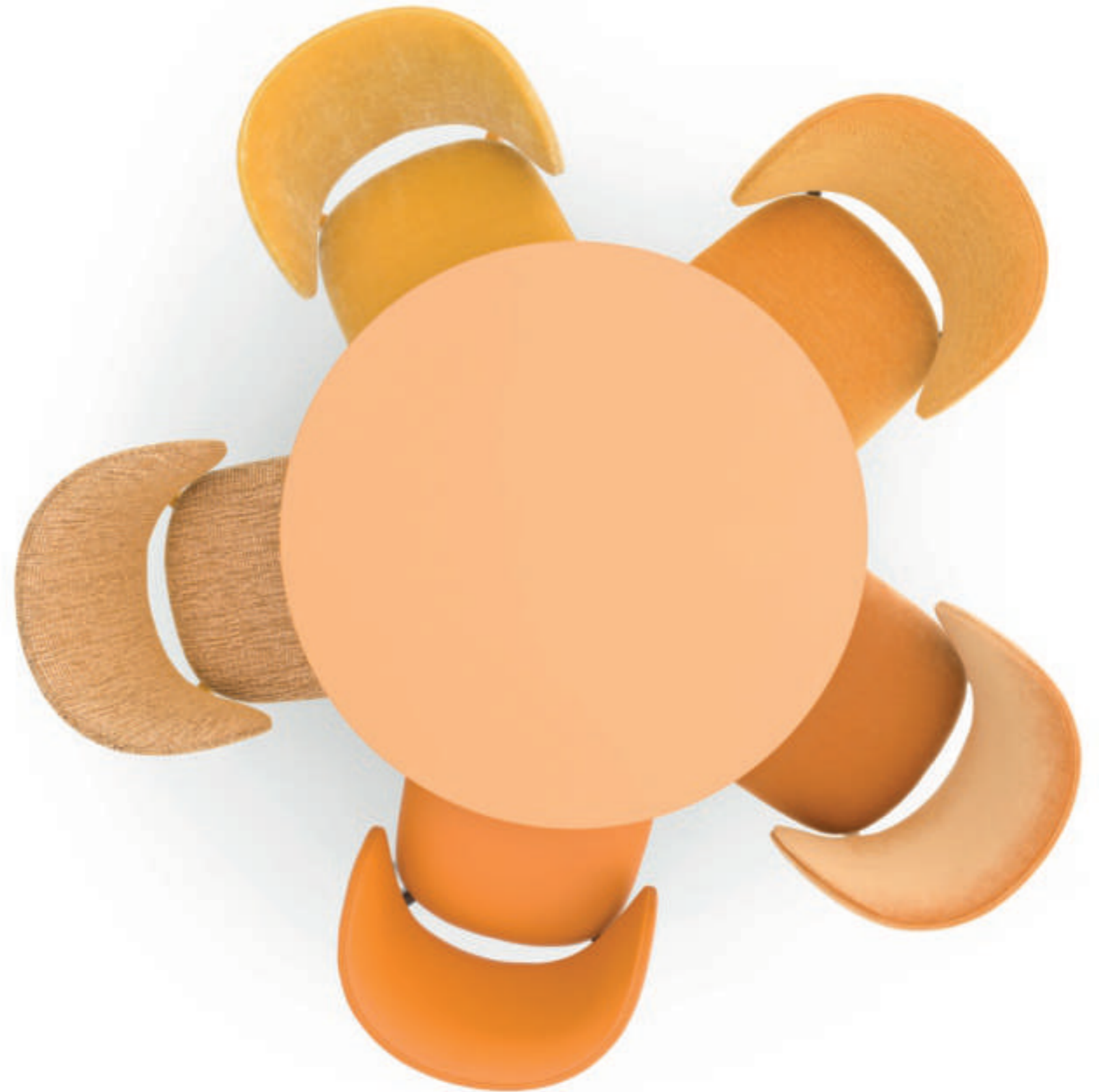



Technical sheet



05011

L.59cm P.62cm
 H.80,5cm H.s.48,5cm
 W.23 1/4" D.24 1/3"
 H.31 2/3" S.h.19"

Bars and casual dining

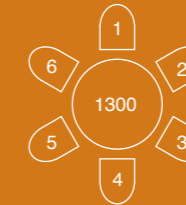
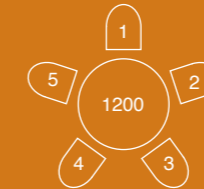
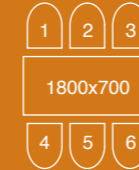
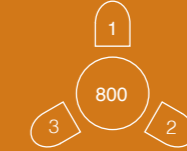
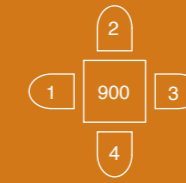

Formal dining

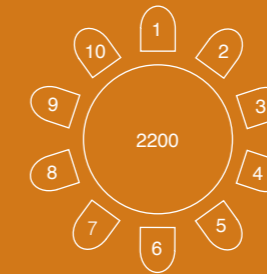
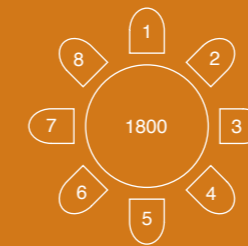
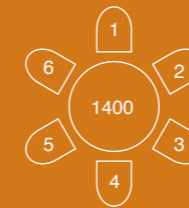
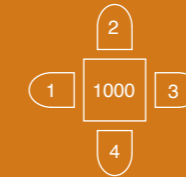



Flor

By Soda Designers
Nasrallah&Horner

Linee rotonde e imbottiture morbide avvolgono
e conferiscono sicurezza per un'esperienza
dell'incontro a 360 gradi.



Watch the video.

ROUND SHAPES AND A SOFT UPHOLSTERY EMBRACES AND OFFER
SECURITY FOR A 360 MEETING EXPERIENCE.



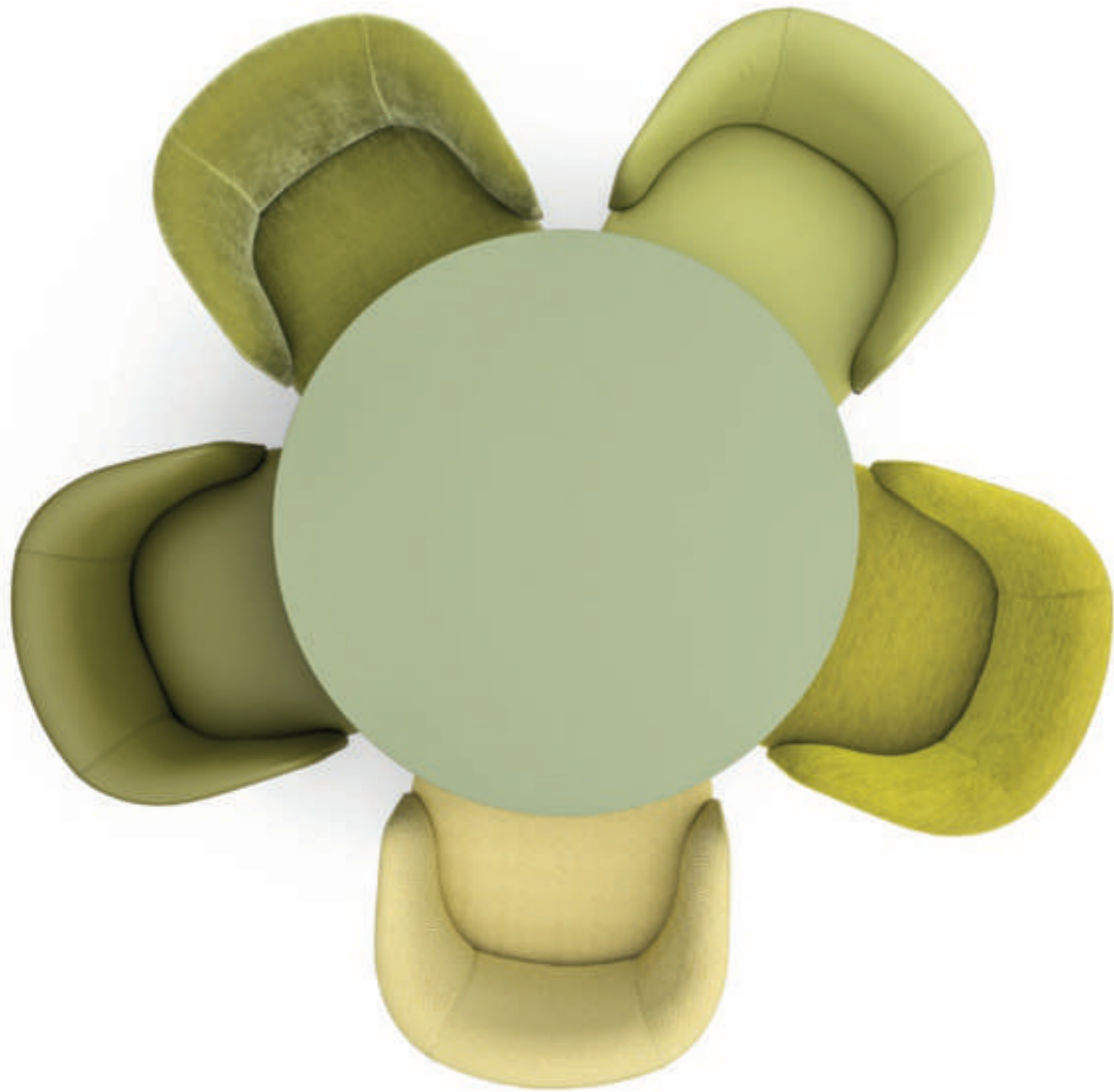

A nostro avviso, una sedia per un ristorante non dovrebbe avere un aspetto diverso da una sedia per l'ambiente domestico. Nella nostra concezione della parola ospitalità l'ospite si deve sentire a casa, e la sedia deve essere comoda, accogliente e spaziosa.

Per realizzare questo obiettivo abbiamo utilizzato linee rotonde e imbottiture morbide enfatizzate dal passaggio fluido dal telaio della sedia alla struttura portante in legno massello.

In our opinion, a chair for restaurant shouldn't look any different than a chair for home ambience. According to our interpretation of the word hospitality the guest should feel at home and the chair should be comfortable, inviting and spacious.

To meet this goal we made use of round lines and soft upholstery, underlined by the flowing transition from the seat shell to the supporting frame made of solid wood.

“La sedia dovrebbe essere comoda accogliente e spaziosa”

“A CHAIR SHOULD BE COMFORTABLE, INVITING AND SPACIOUS”



MONTBEL . 114



FLOR . 115



Technical sheet



04931

L.60,5cm P.59cm
H.81cm H.s.49,5cm

W.23 2/3" D.23 1/4"
H.32 2/3" S.h.19 1/2"

Bars and casual dining

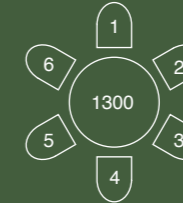
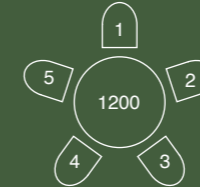
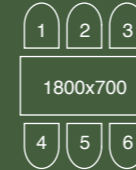
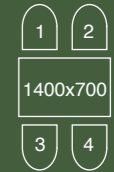
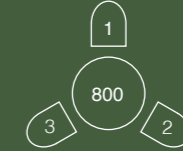
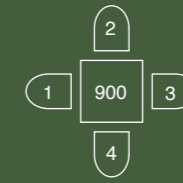

Formal dining

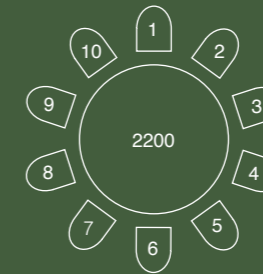
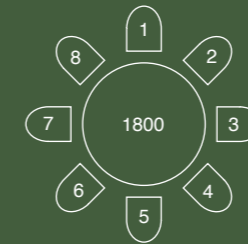
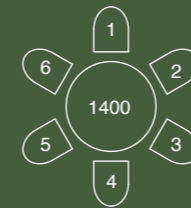
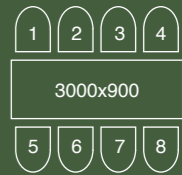
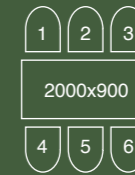
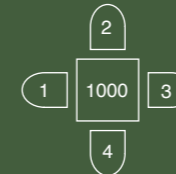

Rose

By Edi & Paolo Ciani

Il look giovane e accattivante di Rose assume una veste ancora più sofisticata e trasversale con le nuove versioni.



Watch the video.

WITH THE NEW VERSIONS, ROSE'S YOUNG, CAPTIVATING LOOKS TAKE ON AN EVEN MORE SOPHISTICATED, TRANSVERSAL APPEARANCE.

MONTBEL . 120



ROSE . 121



La collezione si arricchisce di una nuova seduta dal look sofisticato: la versione pozzetto della originaria/primogenita poltroncina Rose, caratterizzata da una morbida imbottitura fino a terra. Le sue linee eleganti e ricercate conferiscono originalità ad ogni ambiente, come una suite d'albergo o una luxury boutique.

The collection is enriched by a new, sophisticated-looking, item of seating: the "tub" version of the firstborn Rose small armchair, displaying soft upholstery right down to the floor. Its smart, sophisticated lines convey uniqueness to every environment, be it a hotel suite or a luxury boutique.

L'eleganza sposa il comfort
con linee dal fascino discreto.

ELEGANCE AND COMFORT COMBINED, WITH
DISCREETLY FASCINATING LINES.

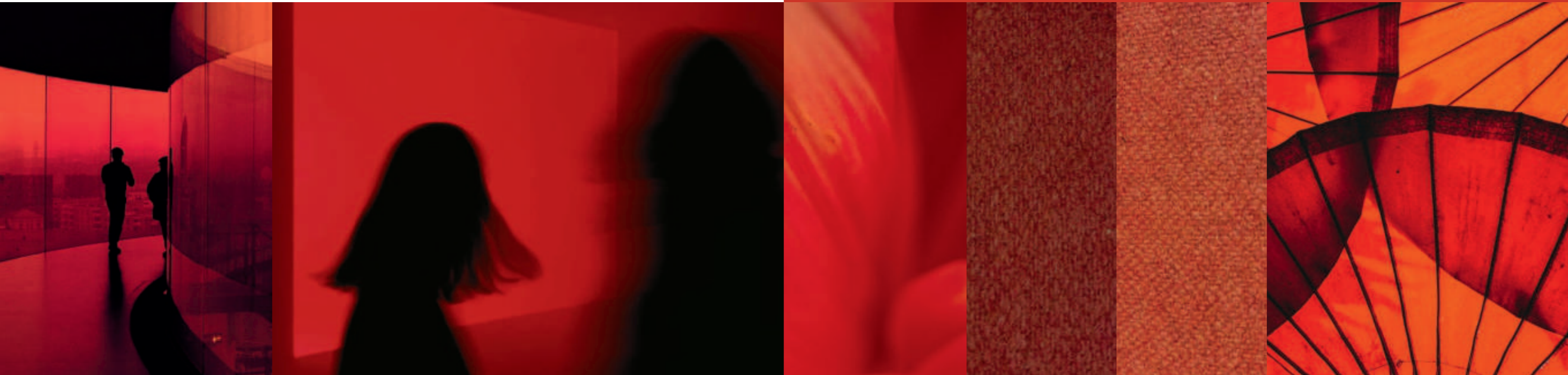



03061L



03071L



03031



03011



03081





03060L



03070L



03030



03010



03080





03084



03034



03014



Metal sabot not available for: 03070L / 03071L / 03079L / 03041 / 03043 / 03051 / 03053 / 03001



Metal sabot not available for: 03070L / 03071L / 03079L / 03041 / 03043 / 03051 / 03053 / 03001



03085L



03015L



03910



03915L



03985L

MONTBEL . 138



ROSE . 139





03934

03930

03931



03984

03981

03980



03934

03931

03930





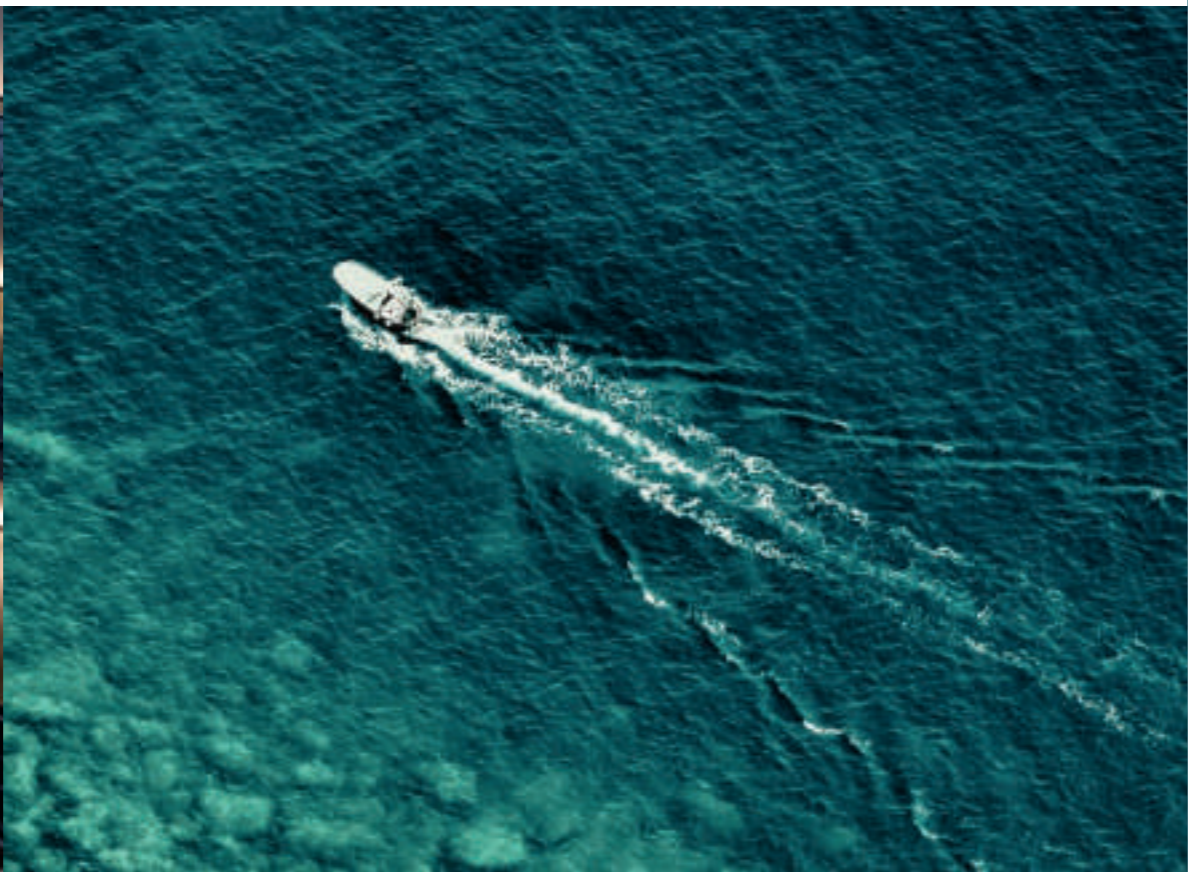

“Linee semplici dalla forma soffice
trasmettono l’idea di uno spazio
intimo e suggestivo”

“SIMPLE LINES WHOSE SOFT SHAPE CONVEY THE IDEA
OF AN INTIMATE, SUGGESTIVE SPACE.”









03001



03043

03001





03041



03051

03001



03941



03951



03941



MONTBEL . 162



ROSE . 163





Technical sheet



03010-03011-03014
L.46cm P.61cm
H.82cm H.s.48cm
W.18" D.24"H.32 1/3"
S.h.19"



03910-03911-03914
L.46cm P.61cm
H.82cm H.s.48cm
W.18" D.24"H.32 1/3"
S.h.19"



03015L-03016L-03019L
L.53cm P.64cm
H.87cm H.s.48,5cm
W.21" D.25" H.25 1/4"
S.h.19"



03915L-03916L-03919L
L.53cm P.64cm
H.87cm H.s.48,5cm
W.21" D.25" H.25 1/4"
S.h.19"



03041-03941-05441
L.83cm P.88cm
H.83,5cm H.s.44,5cm
W.32 2/3" D.34 2/3"
H.33" S.h.17 1/2"



03043-03943-05443
L.95cm P.96cm
H.122cm H.s.44,5cm
W.37 1/2" D.37 3/4"
H.48" S.h.17 1/2"



03039
L.58,5cm P.60,5cm
H.80cm H.s.48,4cm
W.23" D.23 3/4"
H.31 1/2" S.h.19"



03030-03031-03034
L.58,5cm P.60,5cm
H.79,5cm H.s.48cm
W.23" D.23 3/4"
H.31 1/3" S.h.19"



03930-03931-03934
L.59cm P.62cm
H.78cm H.s.48cm
W.23 2/3" D.24 2/3"
H.30 2/3" S.h.19"



03051-03951
L.151cm P.88cm
H.83,5cm H.s.44,5cm
W.59 1/2" D.34 2/3"
H.33" S.h.17 1/2"



03053-03953
L.163cm P.96cm
H.121cm H.s.46cm
W.64 1/4" D.37 3/4"
H.47 2/3" S.h.18 1/4"



03001
L.56,5cm P.56,5cm
H.s.44cm
W.22 1/3" D.22 1/3"
S.h.17 1/3"



05431
L.58,5cm P.60,5cm
H.79,5cm H.s.48cm
W.23" D.23 3/4"
H.31 1/3" S.h.19"



05436
L.58,5cm P.60,5cm
H.80cm H.s.48,5cm
W.23" D.23 3/4"
H.31 1/2" S.h.19"



03060L-03061L
L.67cm P.62cm
H.82cm H.s.48cm
W.26 1/3" D.24 2/3"
H.32 2/3" S.h.19"



03070L-03071L
L.67cm P.62cm
H.76cm H.s.42cm
W.26 1/3" D.24 2/3"
H.30" S.h.16 1/2"



03980-03981-03984
L.45cm P.56,5cm
H.110cm H.s.81,5cm
W.17 2/3" D.22 1/3"
H.43 1/3" S.h.32"



03080-03081-03084
L.45cm P.54cm
H.108,5cm H.s.80cm
W.17 2/3" D.21 1/3"
H.42 2/3" S.h.31 1/2"



03085L-03086L-03089L
L.51cm P.60cm
H.110cm H.s.80cm
W.20" D.23 2/3" H.43 1/3"
S.h.31 1/2"



03960L-03961L
L.67cm P.60cm
H.81cm H.s.48cm
W.26 1/3" D.23 2/3"
H.32" S.h.19"



03970L-03971L
L.67cm P.60cm
H.75cm H.s.42cm
W.26 1/3" D.23 2/3"
H.29 1/2" S.h.16 1/2"



05461L
L.67cm P.62cm
H.82,5cm H.s.48,5cm
W.26 1/3" D.24 2/3"
H.32 1/2" S.h.19"



05463L
L.67cm P.62cm
H.83cm H.s.49cm
W.26 1/3" D.24 2/3"
H.32 3/4" S.h.19"



03985L-03986L-03989L
L.51cm P.60cm
H.111cm H.s.80cm
W.20" D.23 2/3" H.43 3/4"
S.h.31 1/2"

Danielle

By Edi & Paolo Ciani

L'eleganza discreta di Danielle la rende un elemento di arredo versatile ma allo stesso tempo in grado di caratterizzare ambienti raffinati.



Watch the video.

DANIELLE'S DISCREET ELEGANCE MAKES IT A VERSATILE FURNISHING ELEMENT, YET ENABLING IT AT THE SAME TIME TO CHARACTERIZE SOPHISTICATED ENVIRONMENTS.



03681

03611

03631

03635

03615

03685

Programma completo di sedute per soddisfare ogni esigenza di arredamento ed ambienti di classe. Schienale in multistrato stampato, reso morbido da importanti spessori di espanso per garantire un'esperienza di relax totale. Disponibile in due versioni con struttura in legno e in metallo.

A complete seating programme to meet all furnishing demands, and fit in classy locations. The backrest is in printed multilayer material, softened by major foam thicknesses, to ensure an experience of total relaxation. Available in two versions with structure in wood and in metal.

Importanti spessori di espanso garantiscono un'esperienza di relax totale.

MAJOR FOAM THICKNESSES GUARANTEE AN EXPERIENCE OF TOTAL RELAXATION.









03632

03631K



03682

03632

03612

03616

03636

03686





03681K

03611K

03631K

03635K

03615K

03685K

MONTBEL . 186



DANIELLE . 187



03611K



03641

03641K



03641K

03641





MONTBEL . 194



DANIELLE . 195



Technical sheet



03611
L.54cm P.64cm
H.96cm H.s.49,5cm
W.21 1/4" D.25 1/4"
H.37 3/4" S.h.19 1/2"



03611K
L.54cm P.64cm
H.96cm H.s.49,5cm
W.21 1/4" D.25 1/4"
H.37 3/4" S.h.19 1/2"



03612
L.54cm P.64cm
H.96cm H.s.49,5cm
W.21 1/4" D.25 1/4"
H.37 3/4" S.h.19 1/2"



03615
L.54cm P.64cm
H.96cm H.s.49,5cm
W.21 1/4" D.25 1/4"
H.37 3/4" S.h.19 1/2"



03615K
L.54cm P.64cm
H.96cm H.s.49,5cm
W.21 1/4" D.25 1/4"
H.37 3/4" S.h.19 1/2"



03616
L.54cm P.64cm
H.96cm H.s.49,5cm
W.21 1/4" D.25 1/4"
H.37 3/4" S.h.19 1/2"



03631
L.56cm P.64cm
H.92cm H.s.48cm
H.b.66cm
W.22" D.25 1/4"
H.36 1/3" S.h.18 2/3"
A.h.26"



03631K
L.56cm P.64cm
H.92cm H.s.48cm
H.b.66cm
W.22" D.25 1/4"
H.36 1/3" S.h.18 2/3"
A.h.26"



03632
L.56cm P.64cm
H.92cm H.s.48cm
H.b.66cm
W.22" D.25 1/4"
H.36 1/3" S.h.18 2/3"
A.h.26"



03635
L.54cm P.64cm
H.96cm H.s.49,5cm
H.b.66cm
W.21 1/4" D.25 1/4"
H.37 3/4" S.h.19 1/2"
A.h.26"



03635K
L.54cm P.64cm
H.96cm H.s.49,5cm
H.b.66cm
W.21 1/4" D.25 1/4"
H.37 3/4" S.h.19 1/2"
A.h.26"



03636
L.54cm P.64cm
H.96cm H.s.49,5cm
H.b.66cm
W.21 1/4" D.25 1/4"
H.37 3/4" S.h.19 1/2"
A.h.26"



03681
L.48cm P.56,5cm
H.110cm H.s.80cm
W.19" D.22 1/4"
H.43 2/3" S.h.31 1/2"



03681K
L.48cm P.56,5cm
H.110cm H.s.80cm
W.19" D.22 1/4"
H.43 2/3" S.h.31 1/2"



03682
L.48cm P.56,5cm
H.110cm H.s.80cm
W.19" D.22 1/4"
H.43 2/3" S.h.31 1/2"



03685
L.47cm P.58,5cm
H.110cm H.s.80cm
W.18 1/2" D.23"
H.43 2/3" S.h.31 1/2"



03685K
L.47cm P.58,5cm
H.110cm H.s.80cm
W.18 1/2" D.23"
H.43 2/3" S.h.31 1/2"



03686
L.47cm P.58,5cm
H.110cm H.s.80cm
W.18 1/2" D.23"
H.43 2/3" S.h.31 1/2"



03641
L.70cm P.71cm
H.97cm H.s.45,5cm
H.b.65cm
W.27 1/2" D.28"
H.38 1/4" S.h.18"
A.h.25 2/3"



03641K
L.70cm P.71cm
H.97cm H.s.45,5cm
H.b.65cm
W.27 1/2" D.28"
H.38 1/4" S.h.18"
A.h.25 2/3"



03651
L.143cm P.73cm
H.97cm H.s.45cm
W.56 1/3" D.28 2/3"
H.38 1/4" S.h.17 2/3"



03633
L.56cm P.64cm
H.92cm H.s.48cm
H.b.66cm
W.22" D.25 1/4"
H.36 1/3" S.h.18 2/3"
A.h.26"



03637
L.56cm P.64cm
H.93cm H.s.49cm
H.b.67cm
W.22" D.25 1/4"
H.36 3/4" S.h.19"
A.h.26 1/3"



03643
L.70cm P.71cm
H.97cm H.s.45,5cm
H.b.65cm
W.27 1/2" D.28"
H.38 1/4" S.h.18"
A.h.25 2/3"

Bars and casual dining

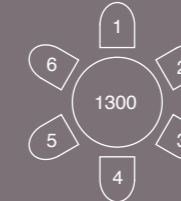
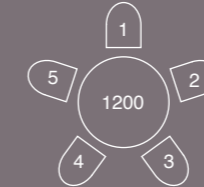
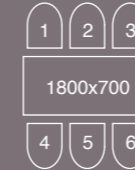
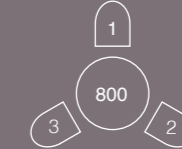
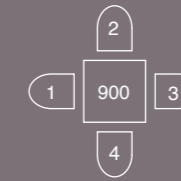

Formal dining

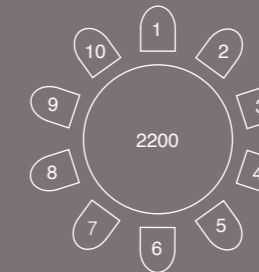
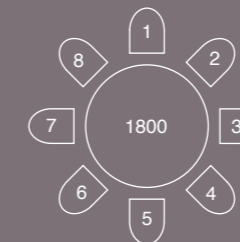
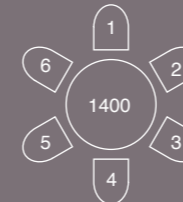
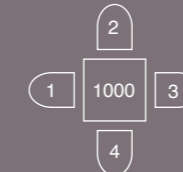



Lily

By Edi&Paolo Ciani

Lily reinterpreta il concetto di hospitality attraverso una veste moderna e giovanile di impatto.



Watch the video.

LILY REINTERPRETS THE CONCEPT OF HOSPITALITY WITH A VERSATILE MODERN AND YOUTHFUL LOOK OF A GREAT IMPACT.



New-entry nella collezione Lily è un'accattivante poltroncina in versione "full upholstery" che presenta un originale basamento fino a terra: scompaiono le classiche gambe in legno o metallo per lasciare spazio ad un pannello sapientemente sagomato e rivestito con morbida imbottitura, a creare un gioco di pieni e vuoti che conferiscono alla poltroncina un look più ricercato, pur mantenendo la linea leggera e giovanile dell'intera collezione.

New-entry to the Lily collection is a captivating small armchair coming in a "full upholstery" version, featuring an original base reaching down to the floor: the classic wooden or metal legs disappear, giving way to an artfully moulded panel, covered in soft padding, so as to generate an interplay of volumes and voids, providing the small armchair with highly-regarded looks, though preserving the light, youthful line of the collection as a whole.

Un gioco di pieni e vuoti caratterizza
l'armonia espressiva delle forme.

AN INTERPLAY OF VOLUMES AND VOIDS CHARACTERISES
THE EXPRESSIVE HARMONY OF THE SHAPES.

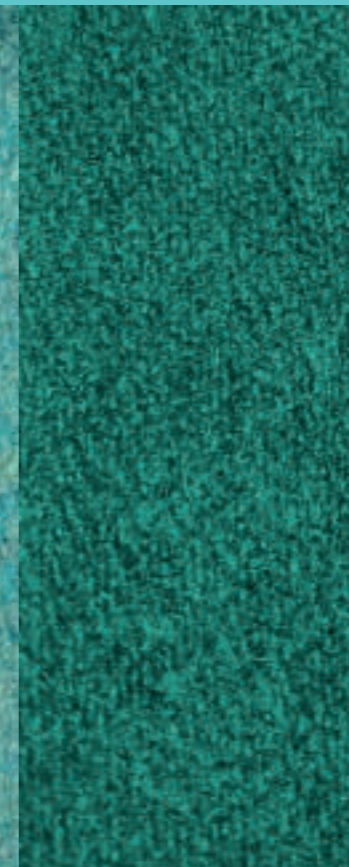
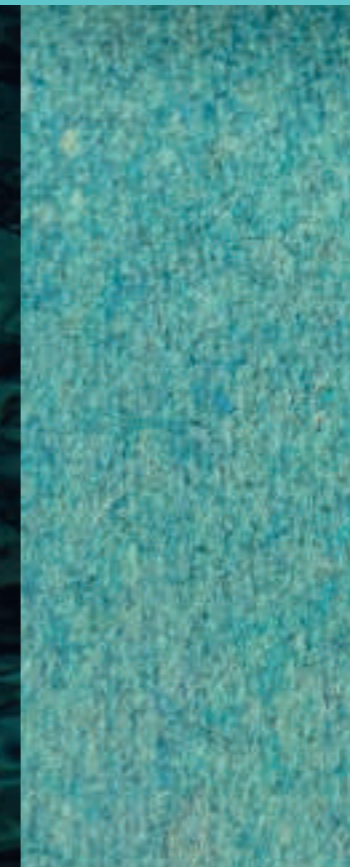
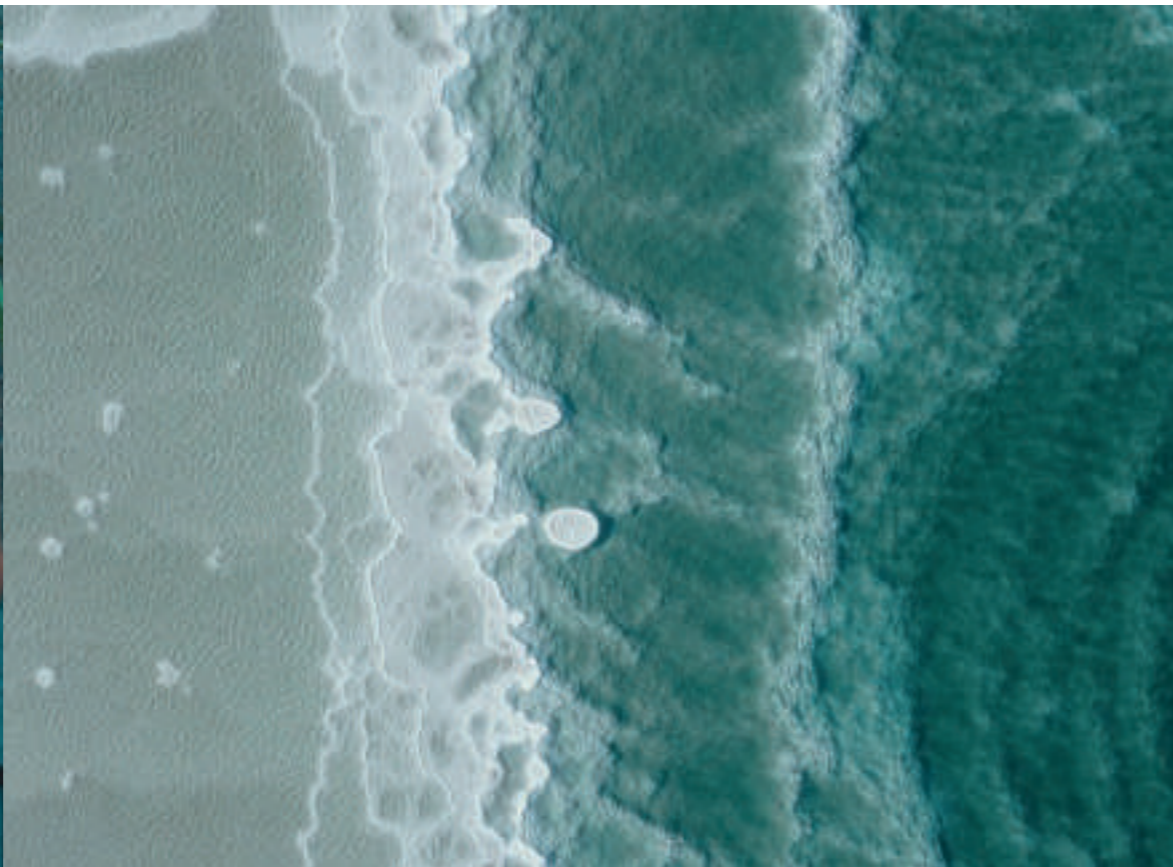







04561L

04571L



04531



04585

04581



04585

04581



04581

04511



04531

04571L

04561L



Technical sheet



04511
L.50cm P.61cm
H.87cm H.s.49cm
W.19 3/4" D.24"
H.38 2/3" H.s.19 1/4"



04515
L.51cm P.58cm
H.87cm H.s.49cm
W.20" D.22 2/3"
H.38 2/3" H.s.19 1/4"



04531
L.61cm P.64cm
H.84cm H.s.48,5cm
W.24" D.25 1/4"
H.33" H.s.19"



04535
L.60cm P.64cm
H.83cm H.s.48,5cm
W.23 2/3" D.25 1/4"
H.32 3/4" H.s.19"



04561L
L.69cm P.68cm
H.85cm H.s.49,5cm
W.27" D.26 3/4"
H.33 1/2" H.s.19 1/2"



04565L
L.69cm P.69cm
H.83cm H.s.49cm
W.27" D.27" H.32 2/3"
H.s.19 1/3"



04571L
L.69cm P.68cm
H.79cm H.s.45cm
W.27" D.26 3/4" H.31"
H.s.17 3/4"



04575L
L.69cm P.68cm
H.79cm H.s.45cm
W.27" D.26 3/4" H.31"
H.s.17 3/4"



04581
L.47cm P.55cm
H.113cm H.s.80cm
W.18 1/2" D.21 2/3"
H.44 1/2" H.s.31 1/2"



04585
L.46cm P.54cm
H.114cm H.s.80cm
W.18" D.21 1/4"
H.44 3/4" H.s.31 1/2"



04539
L.61cm P.64cm
H.84cm H.s.48.5cm



04532
L.61cm P.64cm
H.82,5cm H.s.47cm
W.24" D.25 1/4"
H.32 1/2 H.s.18 1/2"



04533
L.61cm P.64cm
H.83cm H.s.47,5cm
W.24" D.25 1/4"
H.32 3/4 H.s.18 2/3"



04562L
L.69cm P.68cm
H.83cm H.s.47,5cm
W.27" D.26 3/4"
H.32 3/4" H.s.18 2/3"



04563L
L.69cm P.68cm
H.83,5cm H.s.48cm
W.27" D.26 3/4"
H.32 2/3 H.s.18 2/3"

Bars and casual dining

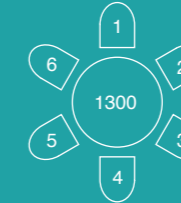
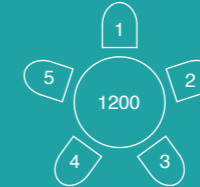
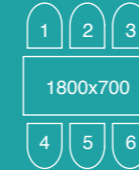
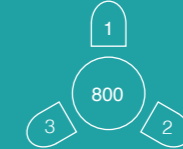
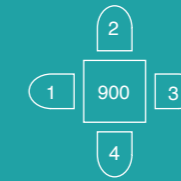

Formal dining

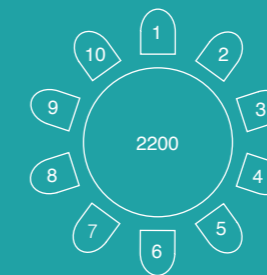
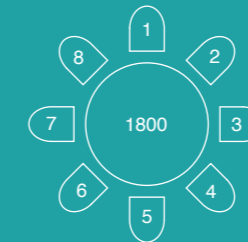
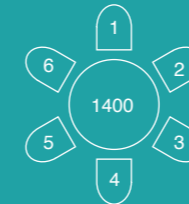
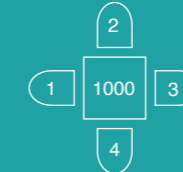



Niky

By Daniele Lo Scalzo Moscheri

Il design compatto si Niky conferisce un look raccolto e familiare a una seduta che si trasforma a seconda del rivestimento e delle finiture per adattarsi a svariati contesti di arredamento.

NIKY'S COMPACT DESIGN BESTOWS COLLECTED, FAMILY LOOKS TO A SEATING ITEM THAT CHANGES, DEPENDING ON ITS COVERING AND FINISHES, TO ADAPT TO VARIOUS FURNISHING SETTINGS.



04721

04725

04721

04715

04711

04715



04715

04715

04725

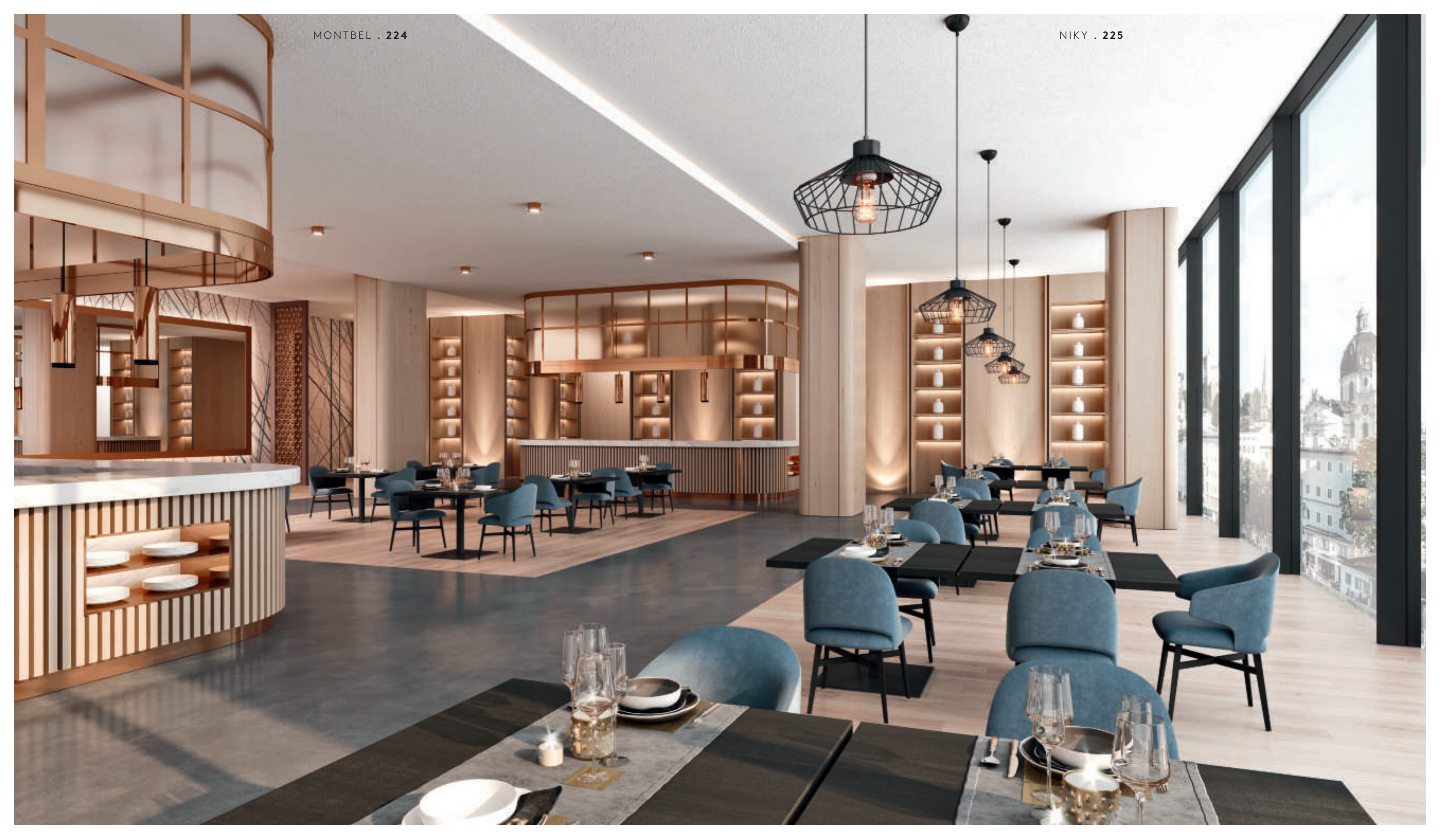



04721



04711



04721



04711

Poltroncina caratterizzata dallo schienale avvolgente che abbraccia il fondo della seduta con un particolare sistema di fissaggio, conferendo uno shape unico distintivo. Disponibile con struttura in legno e metallo in diverse finiture, con tappezzeria in tessuto o pelle.

A small armchair, it features an embracing backrest, encompassing the bottom of the seat with a special attachment system, and endowing it with a unique, distinctive shape. It comes with structure either in wood or in metal in various finishes, with fabric or leather upholstery.

Lo schienale avvolgente rassicura e fa sentire protetti regalando un'esperienza di comfort memorabile.

THE ENRAPTURING BACKREST REASSURES AND MAKES ONE FEEL PROTECTED, GIFTING THE SITTER WITH A MEMORABLE COMFORT EXPERIENCE.

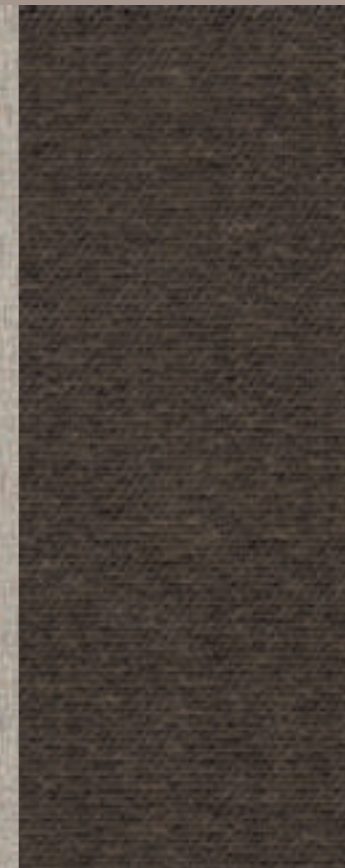

MONTBEL . 230

NIKY . 231



Technical sheet



04711
L.53cm P.54cm
H.87cm H.s.49cm
W.21" D.21 1/4"
H.34 1/4" S.h.19 1/3"



04721
L.56cm P.54cm
H.87cm H.s.49cm
H.b.66cm
W.22" D.21 1/4"
H.34 1/4" S.h.19 1/3"
A.h.26"



04715
L.53cm P.54cm
H.87cm H.s.49cm
W.21" D.21 1/4"
H.34 1/4" S.h.19 1/3"



04725
L.56cm P.54cm
H.87cm H.s.49cm
H.b.66cm
W.22" D.21 1/4"
H.34 1/4" S.h.19 1/3"
A.h.26"

Bars and casual dining

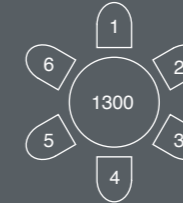
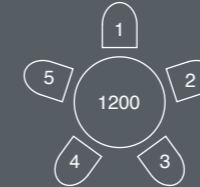
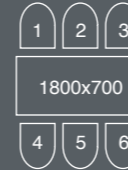
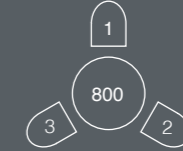
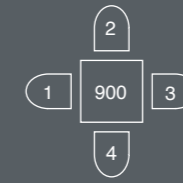

Formal dining

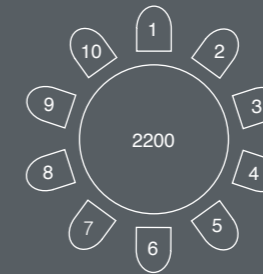
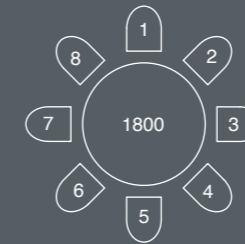
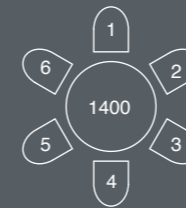
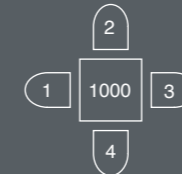



Light

By Edi e Paolo Ciani

Sedute dal look giovanile e dinamico che si distinguono per l'ampia tenuta d'uso.

SEATING ITEMS WITH A YOUTHFUL, DYNAMIC APPEARANCE,
DISTINGUISHING THEMSELVES FOR THEIR LONG DURABILITY.



03282

03212

03222



03221

03211

03281

Collezione di sedute in legno massello, completato da una scocca rivestita in tessuto o pelle, liscia o plissé, adatta ad ambienti giovani e dinamici. La sua forte struttura, garantisce la massima tenuta all'uso.

Seating collection made of solid-wood, completed with a shell covered in fabric or leather, either smooth or pleated upholstery fabrics, appropriate for youthful and dynamic types of ambient. Its strong structure guarantees maximum endurance to usage.

Giovane e dinamica
Light si presenta con
una forte struttura
che ne garantisce
la tenuta d'uso.

YOUNG AND DYNAMIC, LIGHT PRESENTS
ITSELF WITH A STRONG STRUCTURE
THAT GUARANTEES DURABILITY.

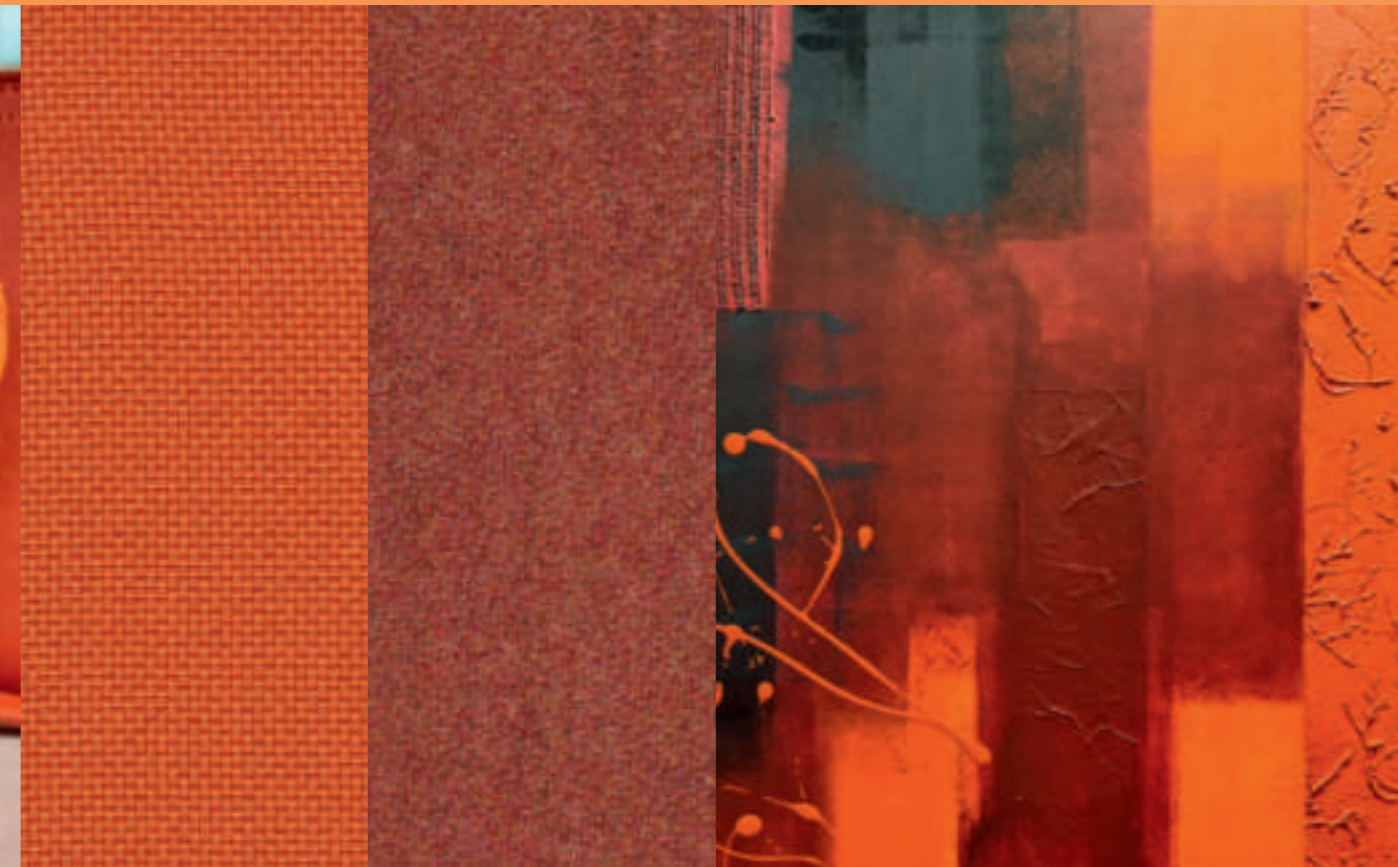
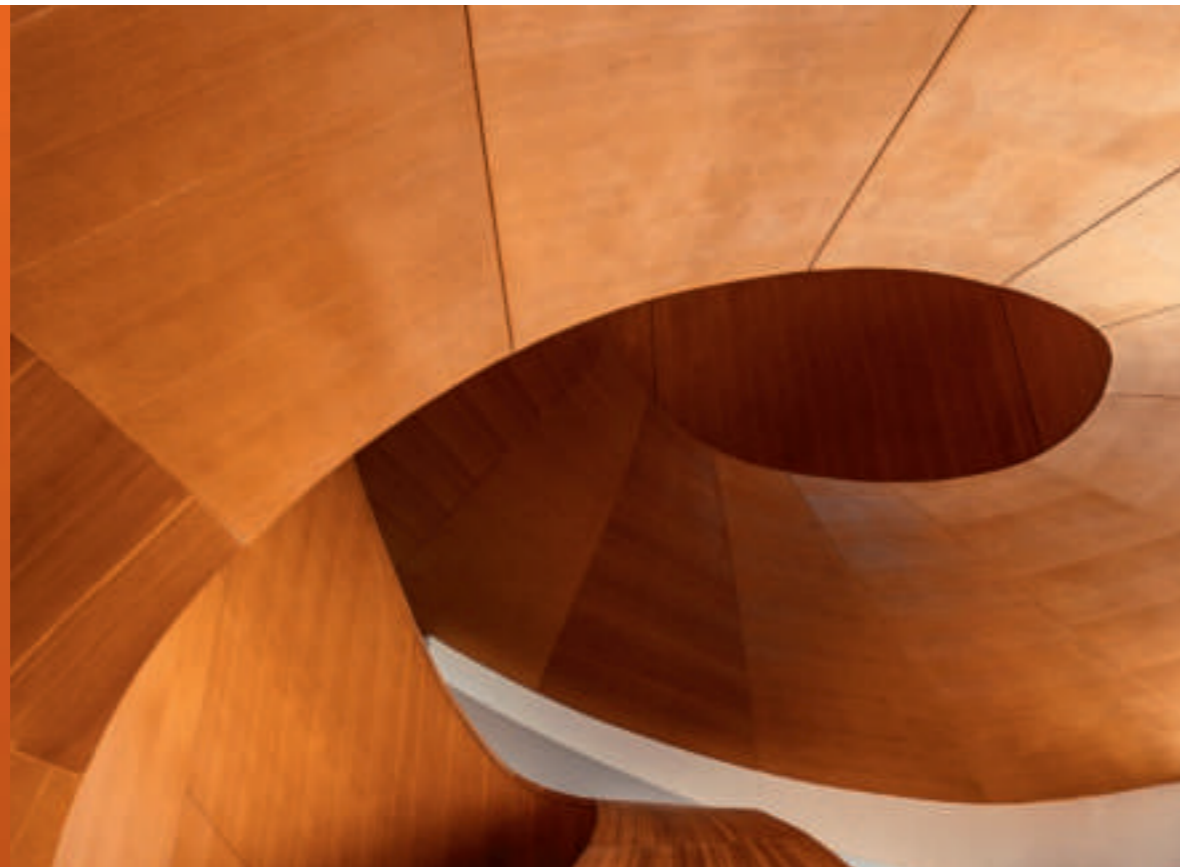



MONTBEL . 242



LIGHT . 243





03215

03235



03215



03281

03282



03281

Technical sheet



03211
 L.46cm P.62cm
 H.86cm H.s.48,5cm
 W.19 2/3" D.24 1/2"
 H.34" S.h.19"



03212
 L.46cm P.62cm
 H.86cm H.s.48,5cm
 W.19 2/3" D.24 1/2"
 H.34" S.h.19"



03215 
 L.52cm P.59,5cm
 H.90cm H.s.48,5cm
 W.20 1/2" D.23 1/2"
 H.35 1/2" S.h.19"



03221
 L.62,5cm P.62cm H.86cm
 H.s.48,5cm H.b.66,5cm
 W.24 2/3" D.24 1/2" H.34"
 S.h.19" A.h.26 1/3"



03222
 L.62,5cm P.62cm H.86cm
 H.s.48,5cm H.b.66,5cm
 W.24 2/3" D.24 1/2" H.34"
 S.h.19" A.h.26 1/3"



03235
 L.57cm P.55cm H.91,5cm
 H.s.48,5cm
 W.22,4 D.21,7
 H.36 S.h.19,1



03281
 L.46cm P.55cm H.103cm
 H.s.78,5cm
 W.19 2/3" D.26"
 H.40 1/2" S.h.31"



03282
 L.46cm P.55cm H.103cm
 H.s.78,5cm
 W.19 2/3" D.26"
 H.40 1/2" S.h.31"

Bars and casual dining

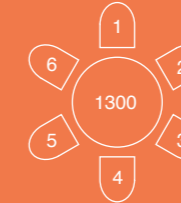
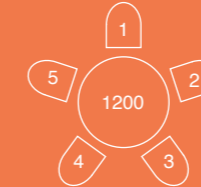
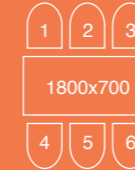
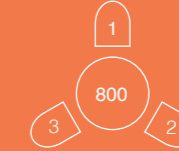
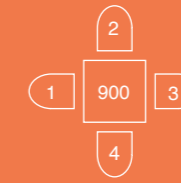

Formal dining

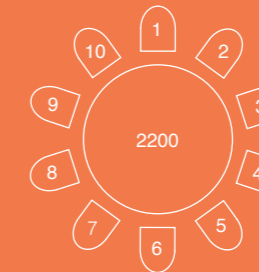
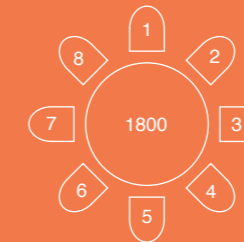
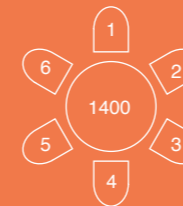
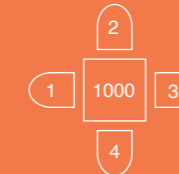

Offset

By Daniele Lo Scalzo Moscheri

Linee essenziali e moderne caratterizzano una seduta solida e allo stesso tempo confortevole dalle molteplici varianti cromatiche.

ESSENTIAL, MODERN LINES CHARACTERIZE THIS SEATING ITEM, SOLID AND AT THE SAME TIME COMFORTABLE, COMING IN A MULTIPLICITY OF COLOURFUL VARIANTS.





02823

02813

02883



02882

Collezione di sedute, essenziale, moderna, ma allo stesso tempo solida e confortevole. Particolarmente versatile grazie alle numerose varianti cromatiche e alla possibilità di comporre la seduta con rivestimenti in pelle o tessuto. Le linee tese nascondono un comfort, il colore laccato e le aniline svelano un linguaggio giovane ed elegante.

A seating collection which is essential and modern while being - at the same time - solid and comfortable. Especially versatile thanks to the myriad colour shades and to the possibility of enriching your seating with either leather or fabric covering. The straight lines conceal the lacquered colours and anilines reveal an elegant, young style.

Il linguaggio giovane ed elegante di questa seduta si esprime attraverso le numerose varianti cromatiche disponibili e la possibilità di abbinare materiali diversi.

THE YOUTHFUL, ELEGANT JARGON OF THIS PIECE OF SEATING EXPRESSES ITSELF THROUGH THE NUMEROUS HUE VARIANTS AVAILABLE, AND THE POSSIBILITY OF MATCHING DIVERSE MATERIALS.





02822



02811



02812



02882

Technical sheet



02811
L.53cm P.54cm
H.85cm H.s.44,5cm
W.20 3/4" D.21 1/3"
H.33 1/2" S.h.17 1/2"



02812
L.53cm P.54cm
H.85cm H.s.47cm
W.20 3/4" D.21 1/3"
H.33 1/2" S.h.18 1/2"



02813
L.53cm P.54cm
H.85cm H.s.47cm
W.20 3/4" D.21 1/3"
H.33 1/2" S.h.18 1/2"



02821
L.61cm P.54cm H.85cm
H.s.44,5cm H.b.65cm
W.24" D.21 1/3" H.33 1/2"
S.h.17 1/2" A.h.25 1/2"



02822
L.61cm P.54cm H.85cm
H.s.47cm H.b.65cm
W.24" D.21 1/3" H.33 1/2"
S.h.18 1/2" A.h.25 1/2"



02823
L.61cm P.54cm H.85cm
H.s.47cm H.b.65cm
W.24" D.21 1/3" H.33 1/2"
S.h.18 1/2" A.h.25 1/2"



02881
L.51,5cm P.52cm
H.104,5cm H.s.75,5cm
W.20 1/4" D.20 1/2"
H.41 1/4" S.h.29 3/4"



02882
L.51,5cm P.52cm
H.104,5cm H.s.78cm
W.20 1/4" D.20 1/2"
H.41 1/4" S.h.30 3/4"



02883
L.51,5cm P.52cm
H.104,5cm H.s.78cm
W.20 1/4" D.20 1/2"
H.41 1/4" S.h.30 3/4"

Bars and casual dining

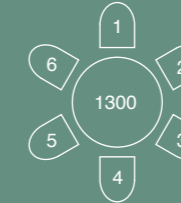
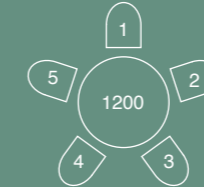
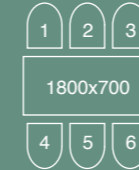
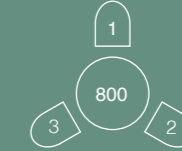
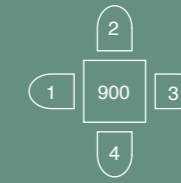

Formal dining

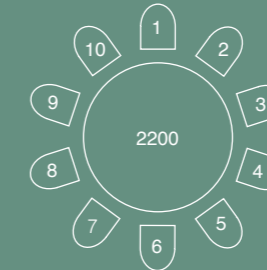
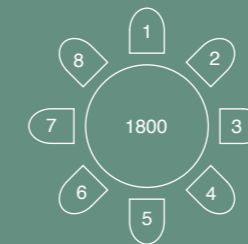
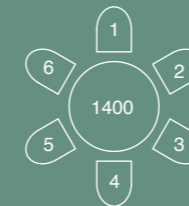
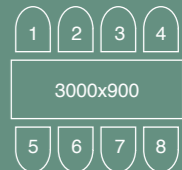
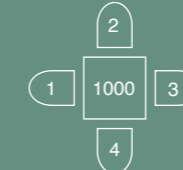

Garbo

By Antonio Minervini

Uno stile nordico dal design senza tempo
adatto a un contract moderno.

A NORDIC STYLE WHOSE DESIGN IS TIMELESS, SUITED TO A MODERN,
CONTRACT ZONE SETTING.





03111



03111K



03121K



03121

Il massello con le sue linee tonde, rende la collezione elegantemente nordica e confortevole. Una collezione senza tempo adatta ad un contract moderno. La tappezzeria sapientemente lavorata, prevede anche un originale capitonné nello schienale. Finitura e tessuti standard e su campione.

Solid-wood - or duramen -, with its rounded lines, makes this collection elegantly Nordic and relaxing. A timeless assortment, appropriate for the modern contract market. The wisely processed upholstery envisions also an originally quilted backrest. Manufactured with standard finishes and fabrics, or customer's own materials.

Un'originale capitonné nello schienale arricchisce una seduta dal design fresco ed elegante.

ORIGINAL CAPITONNÉ IN THE BACKREST ENRICHES A SEATING ITEM WHOSE DESIGN IS REFRESHING AND SMART.

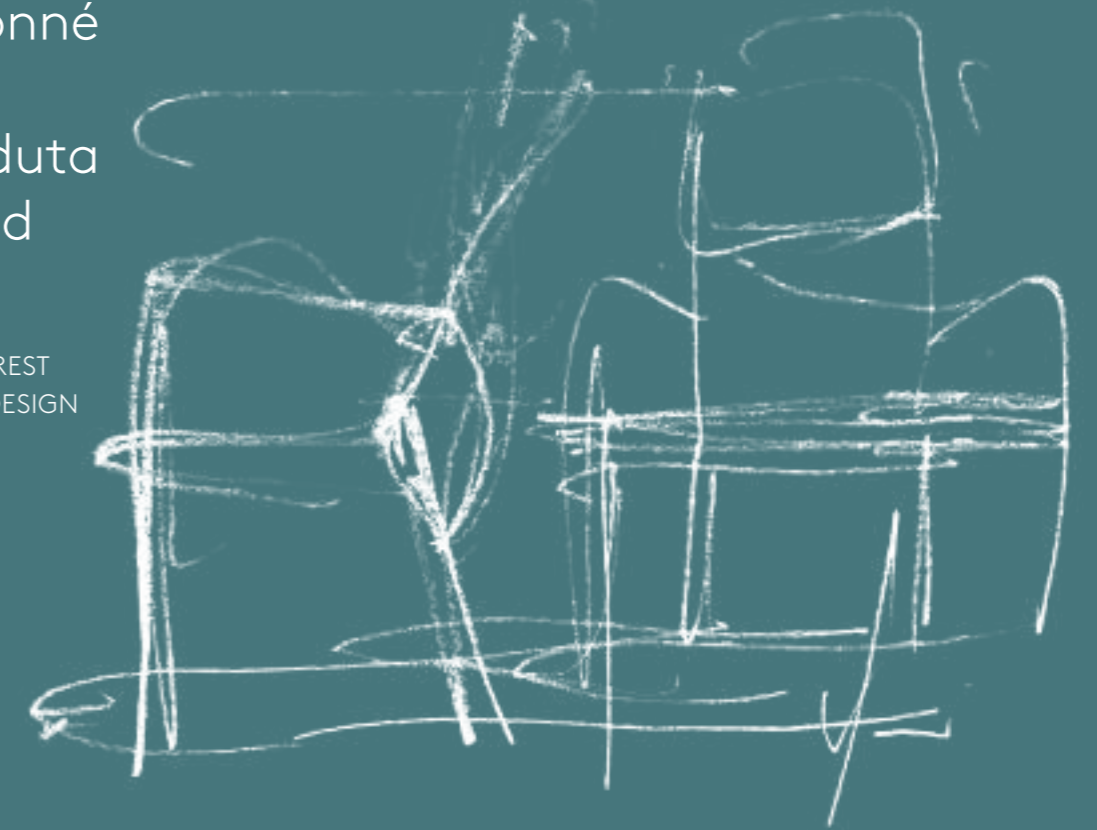



03121K

03111K

03121

03111

03121

MONTBEL . 268

GARBO . 269



Technical sheet



03111

L.49,5cm P.55cm
H.86,5cm H.s.49cm
W.19 1/2" D.21 2/3"
H.34" S.h.19 1/3"



03111K

L.49,5cm P.55cm
H.86,5cm H.s.49cm
W.19 1/2" D.21 2/3"
H.34" S.h.19 1/3"



03121

L.53,5cm P.54cm H.86,5cm
H.s.49cm H.b.69,5cm
W.19 1/2" D.21 1/3" H.34"
S.h.19 1/3" A.h.27 1/3"



03121K

L.53,5cm P.54cm H.86,5cm
H.s.49cm H.b.69,5cm
W.19 1/2" D.21 1/3" H.34"
S.h.19 1/3" A.h.27 1/3"

Bars and casual dining

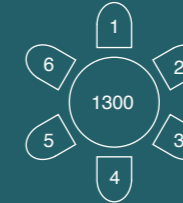
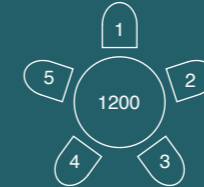
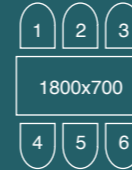
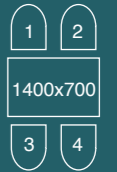
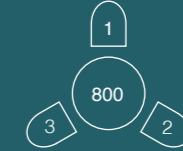
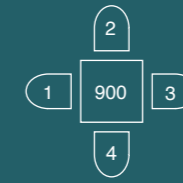

Formal dining

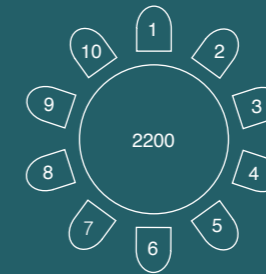
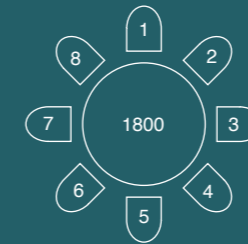
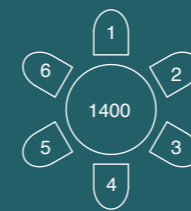
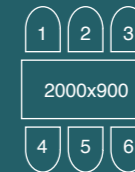
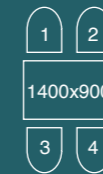
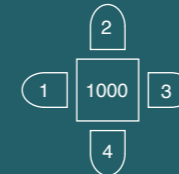



Rivoli

By Daniele Lo Scalzo Moscheri

Il design sofisticato ed elegante di Rivoli rende questa seduta il complemento ideale per arredi di classe.

RIVOLI'S SOPHISTICATED, SMART DESIGN MAKES THIS PIECE OF SEATING THE IDEAL COMPLEMENT FOR CLASSY FURNISHINGS.



03331



03331



03333



03333



Una forma elegante, caratterizza la scocca in poliuretano stampato, morbido, ignifugo, e indeformabile. La parte lignea rigorosamente in massello, rende la Rivoli sofisticatamente adatta ad ambienti di classe. Disponibile sia nella versione tessuto che in pelle, con finiture standard o a campione.

An elegant shape characterizes the shell made of moulded polyurethane foam - soft, fire-repellent and crushproof. The wooden part - manufactured exclusively from solid-wood - makes Rivoli sophisticatedly apt for classy sorts of environment. Available both in the fabric and the leather versions, with either standard or custom-made finishes.

La base in legno massello di questa seduta dichiara uno stile elegante pensato per ambienti ricercati.

THE SOLID WOOD BASE OF THIS SEATING ITEM DECLARES AN ELEGANT STYLE DEVISED FOR SOPHISTICATED ENVIRONMENTS.







Technical sheet



03331

L.57,5cm P.60,5cm
H.86cm H.s.45,5cm
W.22 2/3" D.23 2/3"
H.33 2/3" S.h.18"



03333

L.57,5cm P.60,5cm
H.86cm H.s.45,5cm
W.22 2/3" D.23 2/3"
H.33 2/3" S.h.18"

Bars and casual dining

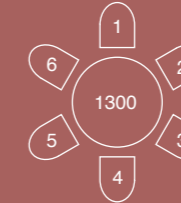
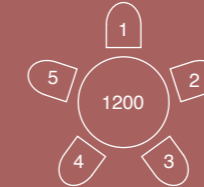
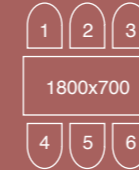
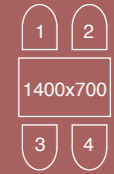
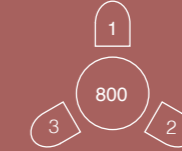
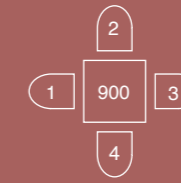

Formal dining

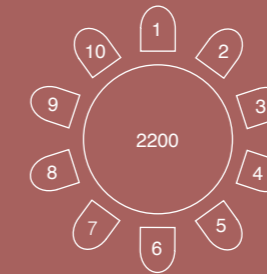
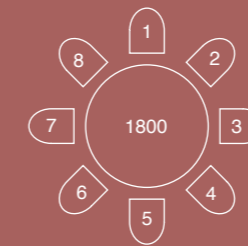
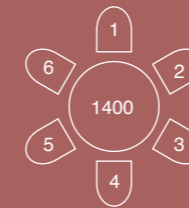
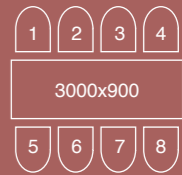
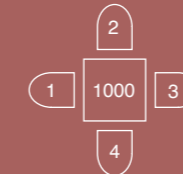



Sayo

By Enzo Berti

Lo schienale in legno massello caratterizza una seduta dalla struttura leggera controbilanciata da una morbida imbottitura.

THE SOLID WOOD BACKREST CHARACTERIZES A SEATING ITEM WITH A LIGHT STRUCTURE COUNTERBALANCED BY SOFT UPHOLSTERY.



Protagonista di questa seduta armoniosa è lo schienale rigorosamente in legno massello realizzato con un unico pezzo curvato con maestria e tecnologia. La leggerezza della struttura è impreziosita dalla tappezzeria disponibili con finiture standard e a campione.

The protagonist of this harmonious piece of seating is the backrest, rigorously in hardwood, made with a single piece, masterly curved, thanks to high-tech means. Its structure lightness is enhanced by the upholstery, available with standard or custom-made finishes.

Lo schienale realizzato con un unico pezzo curvato riflette una maestria artigianale.

THE BACKREST MADE WITH A SINGLE, CURVED PIECE REFLECTS HANDICRAFT MASTERY.

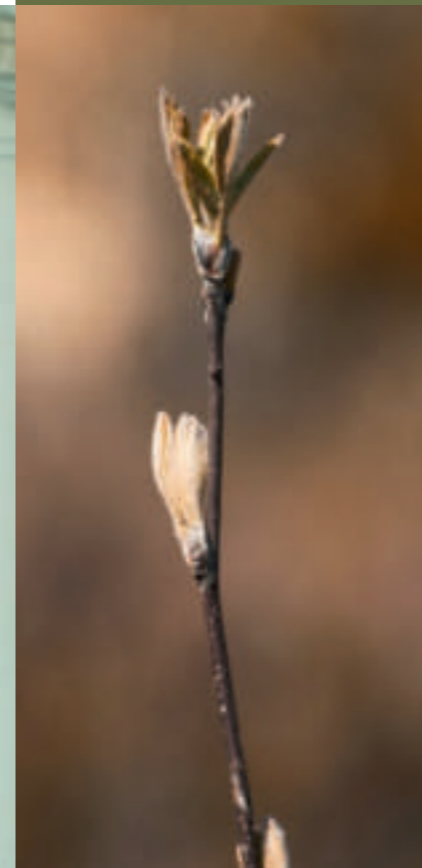

MONTBE . 292



SAYO . 293





Technical sheet



03821

L.58cm P.56cm H.80cm
H.s.48cm H.b.69cm

W.22 2/3" D.22" H.31 1/2"
S.h.18 2/3" A.h.27 1/4"

Bars and casual dining

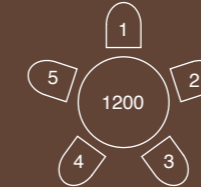
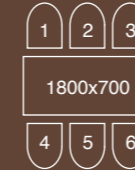
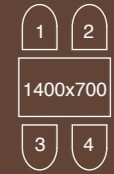
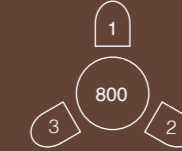
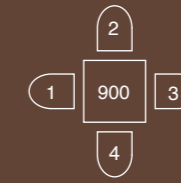

Formal dining

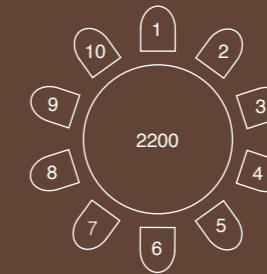
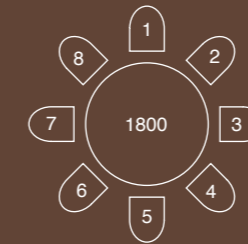
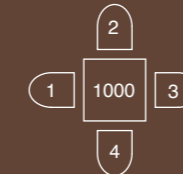



Chanel

By Edi & Paolo Ciani

La collezione di divani componibili grazie alla sua modularità permette un'ampia personalizzazione nelle forme oltre che nelle finiture.



Watch the video.

THANKS TO ITS MODULARITY, THE COLLECTION OF SECTIONAL SOFAS ALLOWS FOR A WIDE PERSONALIZATION BOTH IN SHAPES AND FINISHES.

MONTBEL . 300

CHANEL . 301



MONTBEL . 302



CHANEL . 303





Il progetto Chanel è nato dall'idea di realizzare un divano componibile che, grazie alla sua modularità, permettesse un'ampia personalizzazione nelle forme oltre che nelle finiture. Questo è il valore aggiunto a cui ci siamo ispirati per l'ideazione dei singoli moduli.

Abbiamo scelto delle geometrie facilmente modulabili ed intercambiabili, che dessero spazio alla creatività nella realizzazione di infinite composizioni, semplicemente accostando in modo diverso i vari elementi. Il risultato finale sarà un divano sempre diverso e capace di adattarsi con disinvoltura ad ogni contesto.

La collezione è composta da morbide sedute con o senza schienale, elementi diritti, concavi e convessi; i componenti che fungono da tavolini possono essere utilizzati come side tables se accostati al divano oppure intervallati ai moduli seduta per creare un gioco di pieni e vuoti o ancora come coffee tables se posizionati davanti al divano.

The Chanel project comes from the idea of making a sectional sofa which, thanks to its modularity, would allow for a wide personalization in both shapes and finishes. That is the plus which inspired us to come up with the individual modules.

We chose easily modulable and interchangeable geometries, which would foster creativeness in making infinite compositions, by simply putting together in a different way the various elements. The final result shall be an always diverse sofa, able to adapt with nonchalance to every single type of setting.

The collection is composed of soft seating items, with or without backrest, straight elements, hollow or convex; the components serving as small tables can be used as side tables if put alongside the sofa, or interspersed with the seating modules to create an interplay of solids and voids, or, also, as coffee tables, if placed opposite the sofa.

Geometrie modulari studiate per dare spazio all'espressione compositiva.

MODULAR GEOMETRIES STUDIED TO GIVE SPACE TO THE COMPOSITIONAL EXPRESSION.



MONTBEL . 308

CHANEL . 309





MONTBEL . 312



CHANEL . 313



MONTBEL . 314



CHANEL . 315



MONTBEL . 316

CHANEL . 317



Composizioni

CONFIGURATIONS

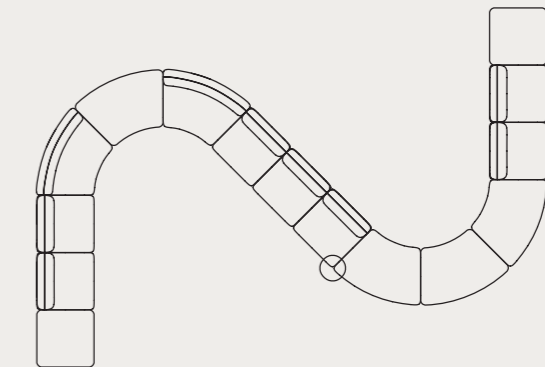
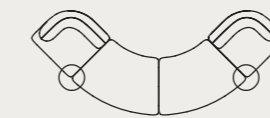
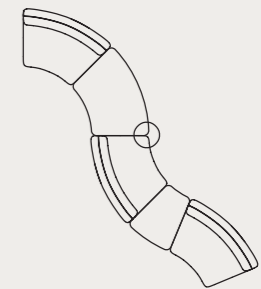
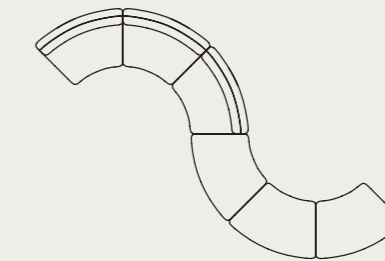
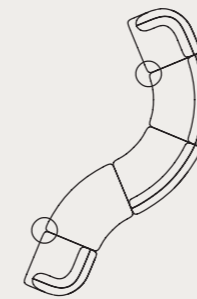
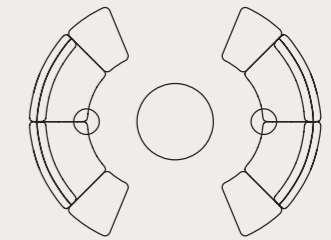
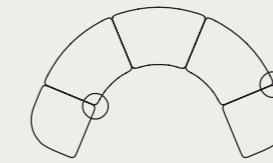
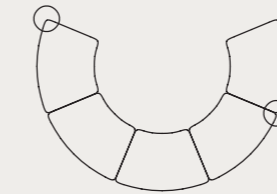
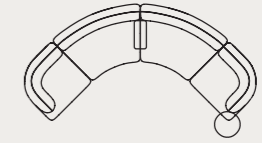
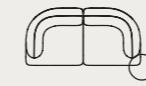

MONTBEL . 320

CHANEL . 321



MONTBEL . 322



CHANEL . 323



Composizioni

CONFIGURATIONS

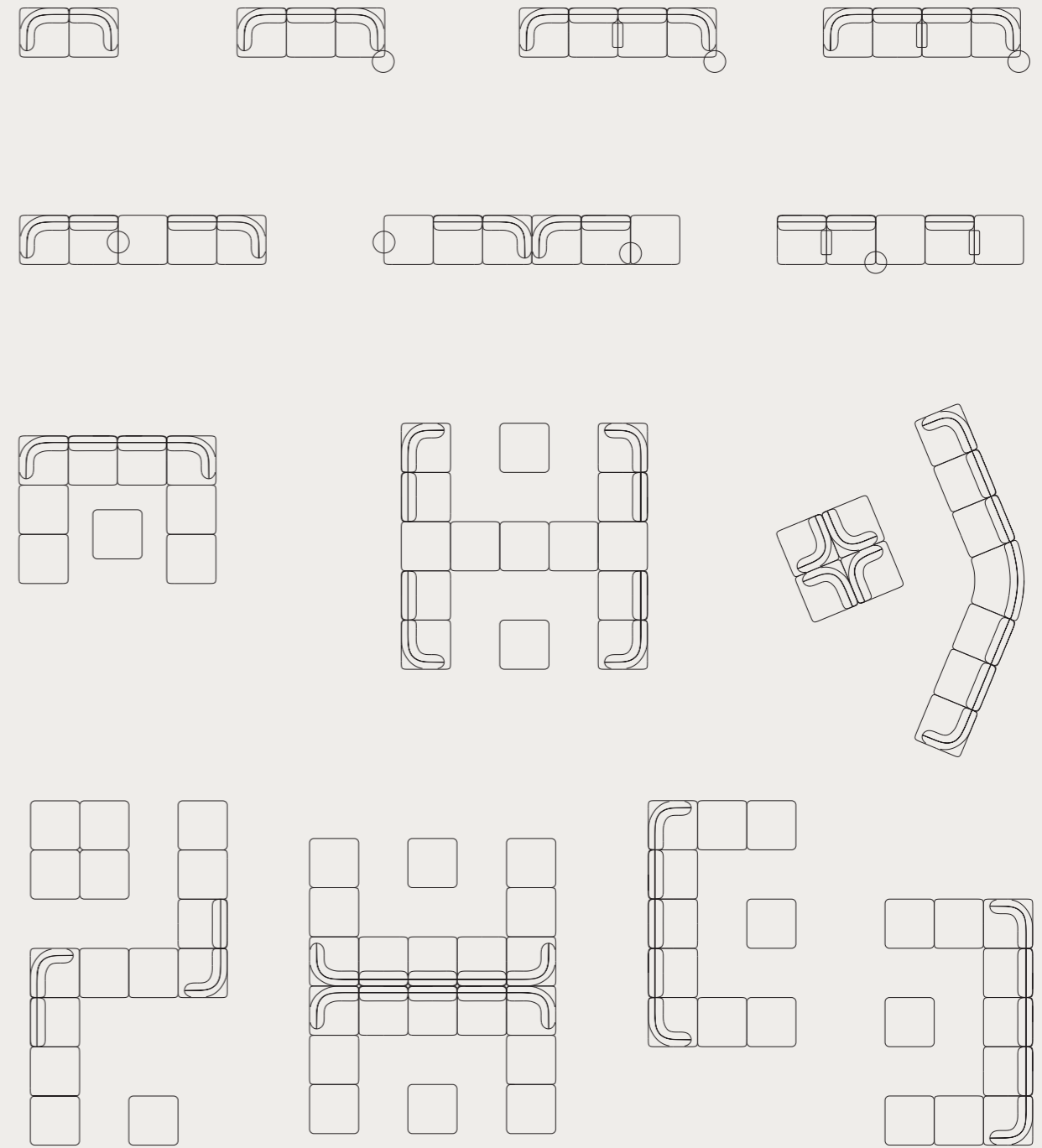

Technical sheet



05550

L.90cm P.90cm H.43cm
H.s.43cm
W.35,4 D.35,4
H.16,9 S.h.16,9



05551

L.90cm P.90cm H.43cm
H.s.43cm
W.35,4 D.35,4
H.16,9 S.h.16,9



05552 DX

L.90cm P.90cm H.79cm
H.s.43cm
W.35,4 D.35,4
H.31,1 S.h.16,9



05553 SX

L.90cm P.90cm H.79cm
H.s.43cm
W.35,4 D.35,4
H.31,1 S.h.16,9



05554

L.90cm P.90cm H.43cm
H.s.43cm
W.35,4 D.35,4
H.16,9 S.h.16,9



05555 DX

L.90cm P.90cm H.79cm
H.s.43cm
W.35,4 D.35,4
H.31,1 S.h.16,9



05556 SX

L.90cm P.90cm H.79cm
H.s.43cm
W.35,4 D.35,4
H.31,1 S.h.16,9



05557

L.110cm P.110cm
H.43cm H.s.43cm
W.43,3 D.43,3
H.16,9 S.h.16,9



05558

L.110cm P.110cm
H.79cm H.s.43cm
W.43,3 D.43,3
H.31,1 S.h.16,9



05580-05581

L.90cm P.90cm H.33cm
W.35,4 D.35,4
H.13



05587-05588

L.110cm P.110cm
H.33cm
W.43,3 D.43,3
H.13



05598-05599

L.40cm P.40cm H.54cm
W. 17,7 D.15,5
H.21,3



Star

By Edi e Paolo Ciani

Un grande divano che si rende protagonista di spazi importanti e di prestigio.

A MONUMENTAL SOFA CAN BECOME THE PROTAGONIST OF IMPORTANT AND PRETIGIOUS VENUES.



Un'onda morbida e sinuosa caratterizza il grande divano che si rende protagonista di spazi importanti e di prestigio. Le dimensioni possono essere personalizzate, mantenendo stabile l'elemento centrale per potersi adattare alle più svariate esigenze compositive, a spazi più o meno ampi.

A soft, sinuous wave characterises the large settee that becomes the protagonist of important, prestigious spaces. Its sizes can be custom-made, while its central element remains stable, so that it can meet the most diverse compositional requirements, whatever the width of the room it is going to fit into.

La sinuosità di un tratto prende forma in un divano dalla forma iconica.

THE SINUOUSNESS OF A LINE
TAKES ON THE SHAPE OF
AN ICON-SHAPED SOFA.

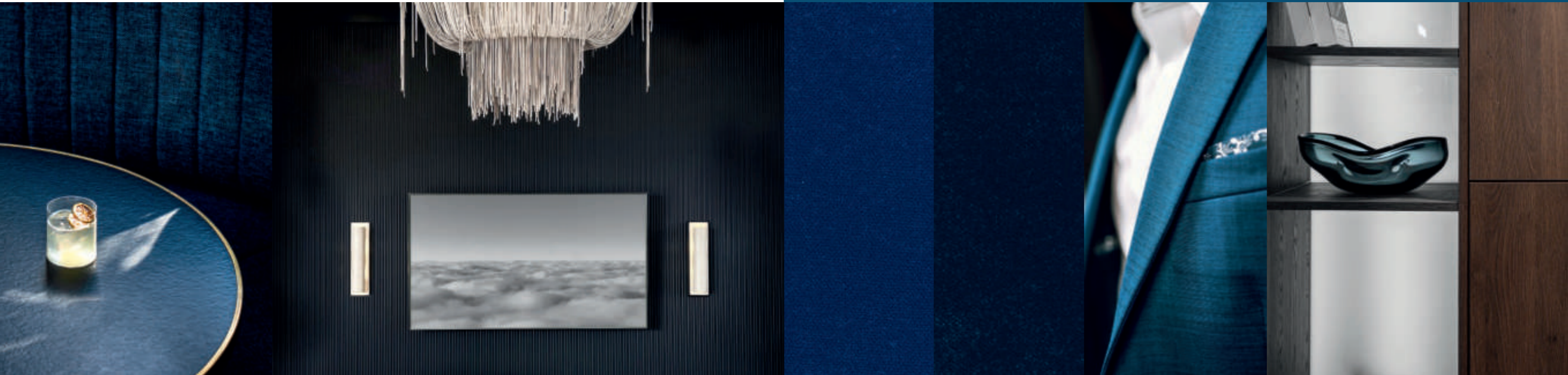
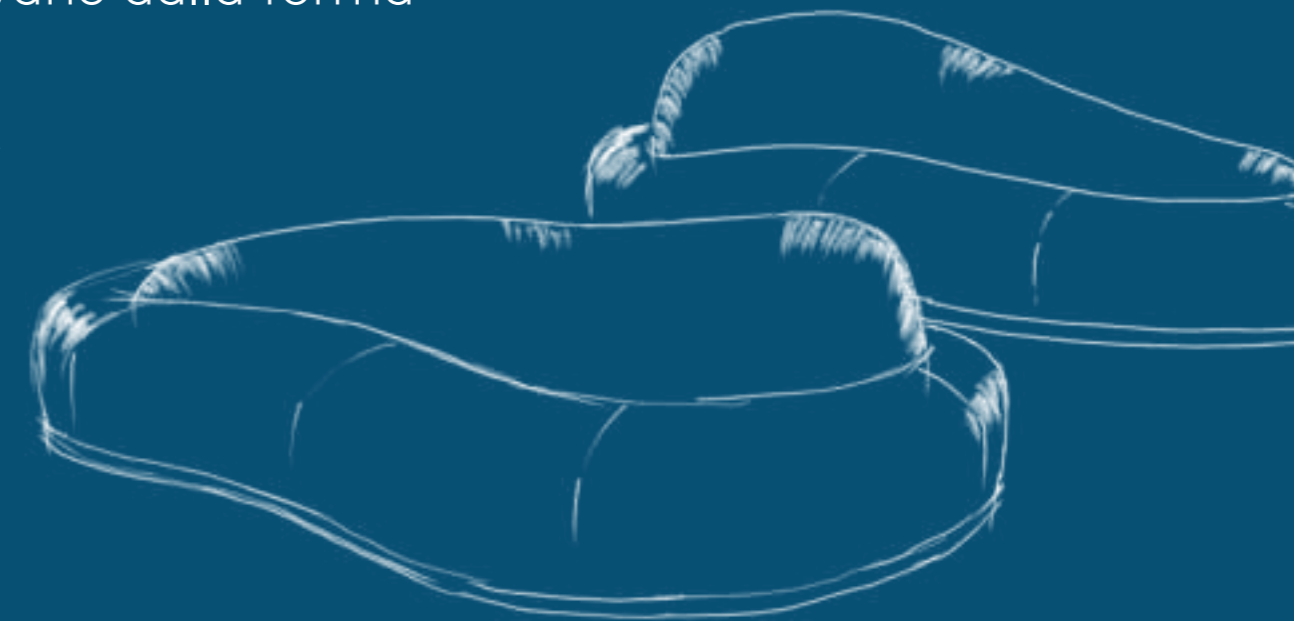

MONTBEL . 334

STAR . 335

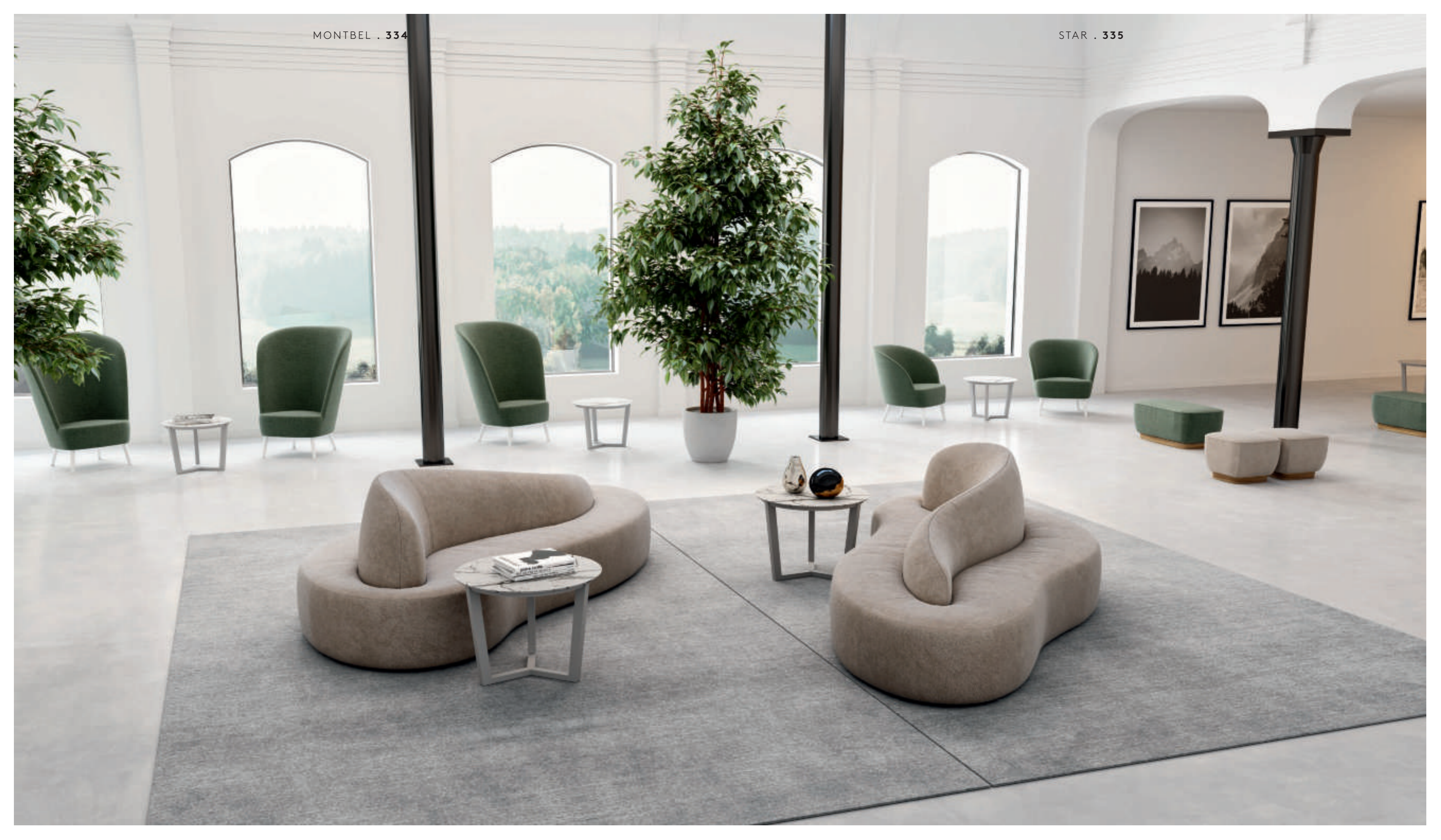



04451
STANDARD DIMENSION

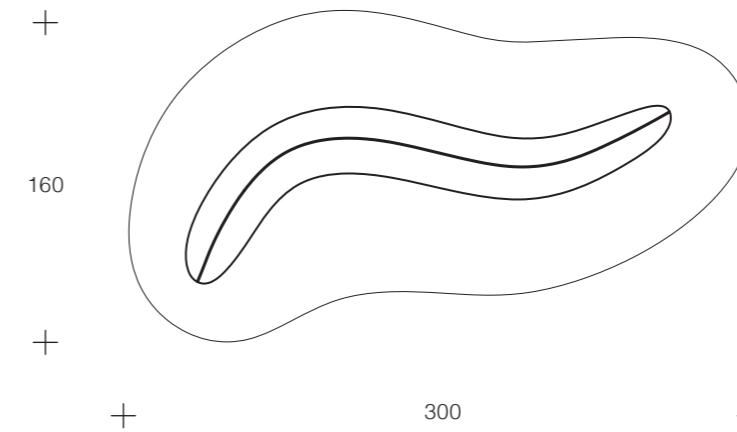

CUSTOM DIMENSION

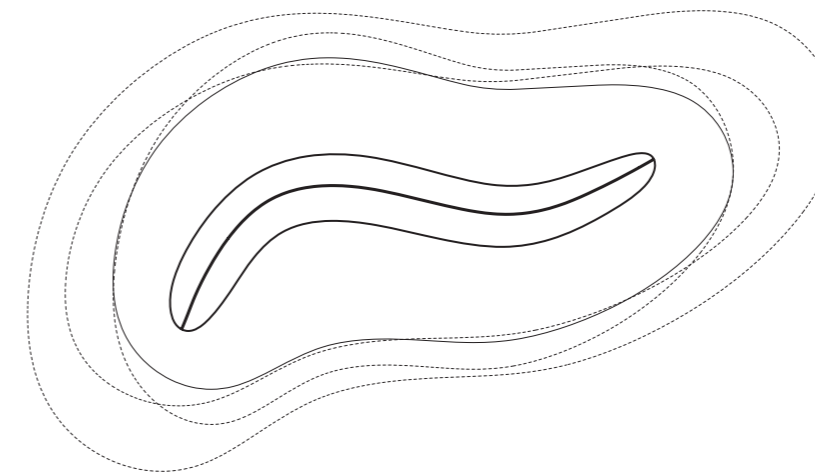

Star custom

Il divano star si inserisce armoniosamente in spazi e ambienti differenti adattando le sue dimensioni per le più svariate esigenze compositive. Mantenendo invariato l'elemento centrale infatti si può modificare la seduta sia in larghezza che in lunghezza.

The "STAR" sofa fits in harmoniously whatever the room or other environment it is destined to, while its sizes can adapt to the most varying requirements depending on what you want to put together with it. As a matter of fact, by keeping the central element of this piece of seating unchanged, both its width and length can be extended.



Technical sheet



04451

L.300cm P.160cm

H.s.45cm H.95cm

W.118" D.63"

S.h.17 2/3" H.37 1/2"

Euforia Air

By Edi & Paolo Ciani

La passione per l'artigiano e tecniche di produzione all'avanguardia si incontrano per dare vita a sedute di forte impatto estetico e straordinaria personalità.



Watch the video.

AN ARTISAN'S PASSION AND IN-THE-VAN PRODUCTION TECHNIQUES GET TOGETHER AND GENERATE SEATING ITEMS WHOSE APPEARANCE LEAVES A POWERFUL IMPACT, DISPLAYING AN UNCOMMON PERSONALITY.











Euforia Air nasce da mani esperte che coniugano la passione dell'artigiano con le tecniche di produzione più moderne, dando vita a sedute di forte impatto estetico e straordinaria personalità.

Divani e poltrone iconiche, che ben si adattano a molteplici ambienti grazie alla possibilità di scegliere il basamento in legno oppure in metallo, entrambi con svariate finiture a disposizione.

L'eleganza dello schienale, caratterizzato da un'unica curva armoniosa, abbraccia il morbido sedile, dando vita ad una collezione di sedute confortevoli, accoglienti e solide, grazie all'uso del poliuretano espanso e alla forte struttura in legno che garantisce la massima tenuta, il tutto rivestito da generose imbottiture e da una ricca tappezzeria curata con maestria sartoriale.

Giocando con gli accostamenti di tessuti, pellami e finiture, si ottengono soluzioni personalizzate ed esclusive, che impreziosiscono ogni contesto: da quelli in stile Modern Design, a quelli dal respiro più classico e Retrò Chic, a location dall'anima Industrial vintage e Urban Jungle.

Euforia Air is born from expert hands, combining an artisan's passion with the most modern production techniques, this in turn brings about seating items whose style and tremendous character yield a strong impression.

Iconic sofas and armchairs that well suit a multiplicity of environments, and you may choose their base, either wooden or of metal, both coming with a number of available finishes.

The elegance of the backrest, characterised by a single harmonious curve, hugs the soft seat, generating a collection of comfortable seating items, welcoming and solid, thanks to the use of polyurethane foam and the robust wooden structure, guaranteeing utmost resistance, the whole covered with generous padding and a rich upholstery, finished with sartorial mastery.

By playing with matched fabrics, leathers and finishes, one obtains custom-made, exclusive solutions, enriching whatever context: from the Modern Design style one to those of a more classic and "Retro-Chic" flair, to locations with an Industrial vintage and Urban Jungle soul.

L'eleganza di una curva si fa icona nell'abbraccio dello schienale.

THE ELEGANCE OF A BEND BECOMES AN ICON, WITH ITS ENRAPTURING BACKREST.

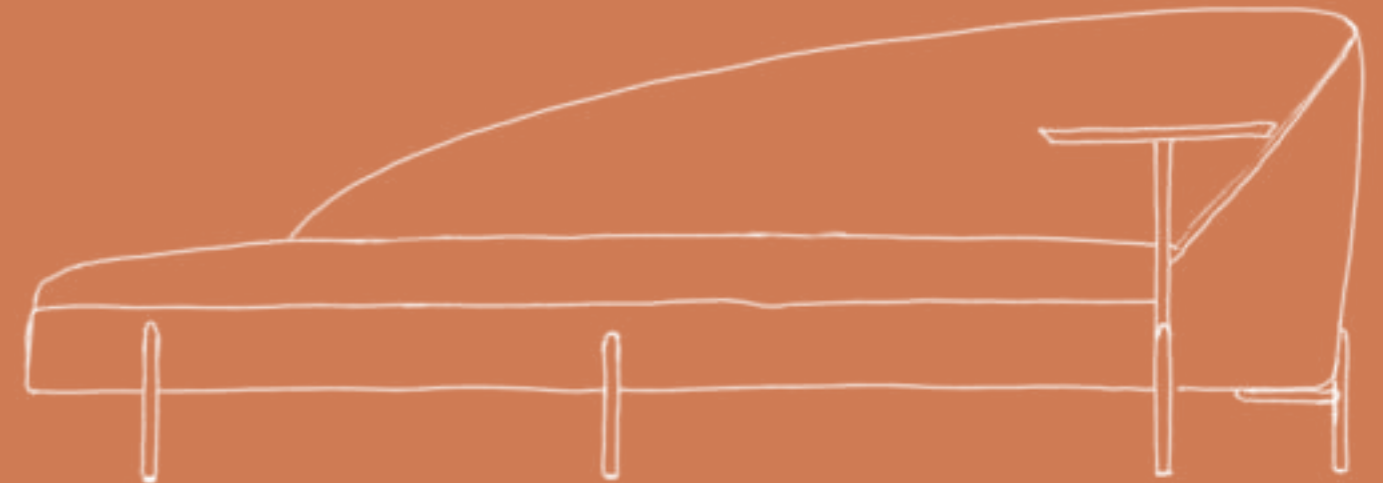

Technical sheet



05363-05366

L.92cm P.82cm H.78cm H.s.43cm
W.36 1/4" D.32 1/3" H.30 3/4" S.h.17"



05364-05367

L.92cm P.82cm H.78cm H.s.43cm
W.36 1/4" D.32 1/3" H.30 3/4" S.h.17"



05365-05368

L.88cm P.87cm H.78cm H.s.43cm
W.34 3/4" D.34 1/4" H.30 3/4" S.h.17"



05353-05355

L.236cm P.106cm H.82cm H.s.43cm
W.93" D.41 3/4" H.32 1/4" S.h.17"



05354-05356

L.236cm P.106cm H.82cm H.s.43cm
W.93 1/4" D.41 3/4" H.32 1/4" S.h.17"

Euforia System

By Edi & Paolo Ciani

La ricchezza compositiva della collezione Euforia System consente di sviluppare configurazioni personalizzate adatte sia al mondo domestico che contract.

THE COMPOSITIONAL WEALTH OF THE EUFORIA SYSTEM'S COLLECTION
ALLOWS TO DEVELOP PERSONALIZED CONFIGURATIONS SUITABLE TO BOTH
THE HOME AND THE CONTRACT WORLDS.

The compositions

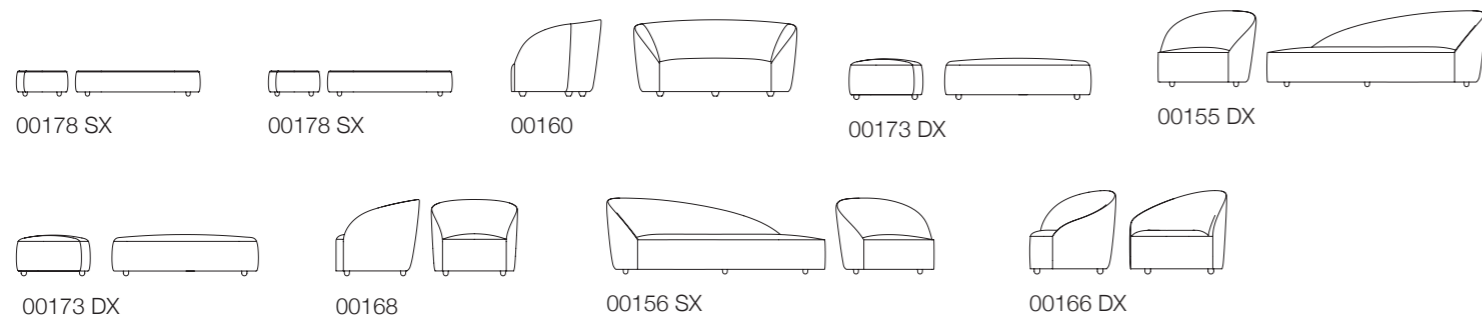
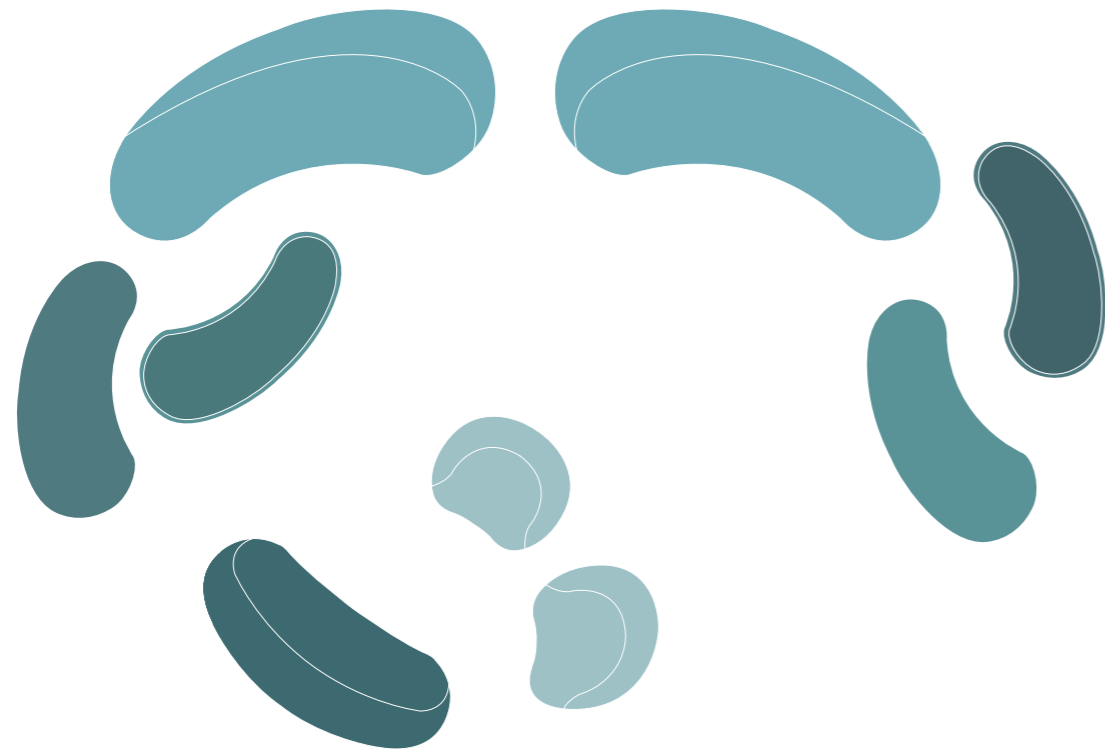

La molteplicità degli elementi e le forme morbide e sinuose di Euforia System permettono di creare infinite composizioni che possano rispondere a diverse esigenze e stili.

The variety of the elements as well as the soft and sinuous forms of Euforia System allow to create endless compositions that can meet various requirements and styles.

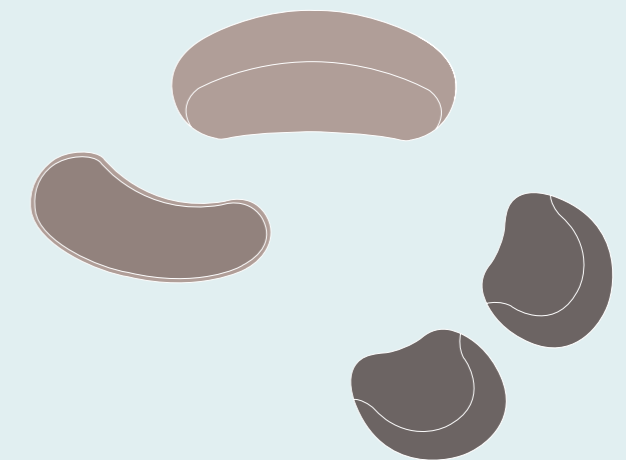
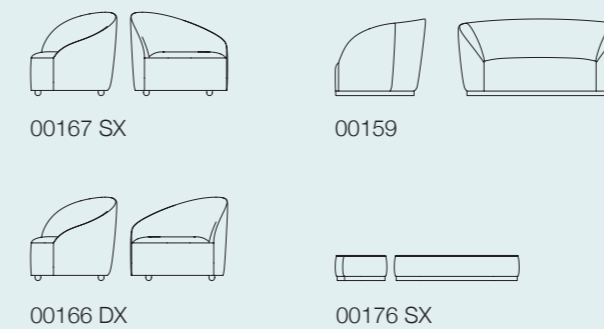
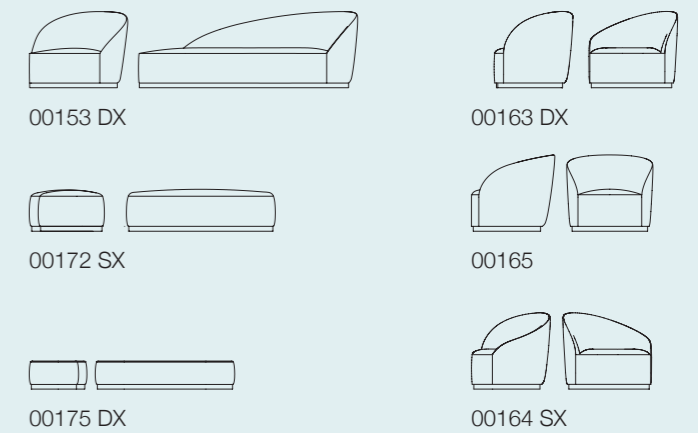
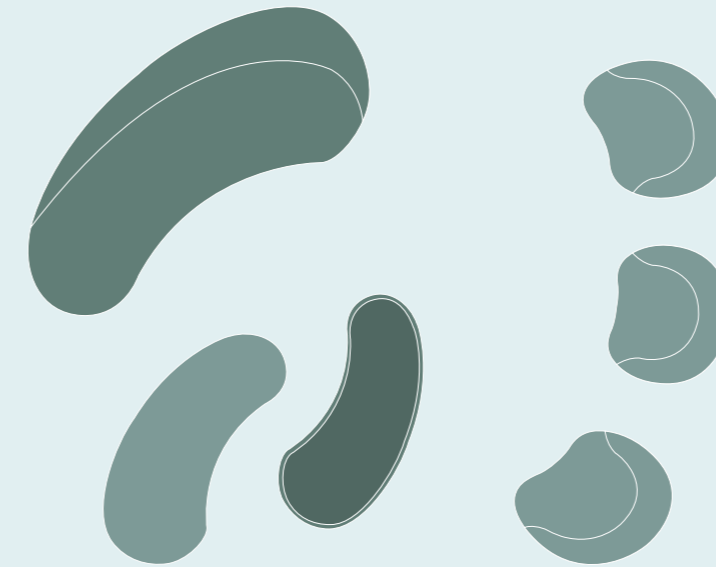



00163DX



00165



00164SX





00166DX

00177DX

00173DX

00155DX

00156SX

00173DX

00178SX

00167SX

Euforia System si compone di innovativi divani con lo schienale in poliuretano espanso e "isole" imbottite dal morbido design.

La collezione si completa con le tre confortevoli maxi poltrone e i tavolini coordinati. Una ricca scelta di cuscini esaurisce il panorama arredativo della collezione Euforia, consentendo soluzioni eleganti e personalizzate sia negli spazi domestici che nelle aree del contract e dell'hotellerie.

Euforia System comprises innovative settees with the backrest made of polyurethane foam and upholstered "isles" designed to be soft.

The collection is completed with three comfortable lounge chairs and coordinated coffee tables. A wide selection of loose cushions completes the Euforia panorama, harmonizing elegant and bespoke solutions for both the domestic, contract and hospitality markets.

Incontrarsi nella circolarità dell'isola per perdersi in molteplici combinazioni.

GATHERING TOGETHER IN THE CIRCULAR ISLAND OF THE SOFAS TO GET LOST IN THEIR MULTIPLE COMBINATIONS.

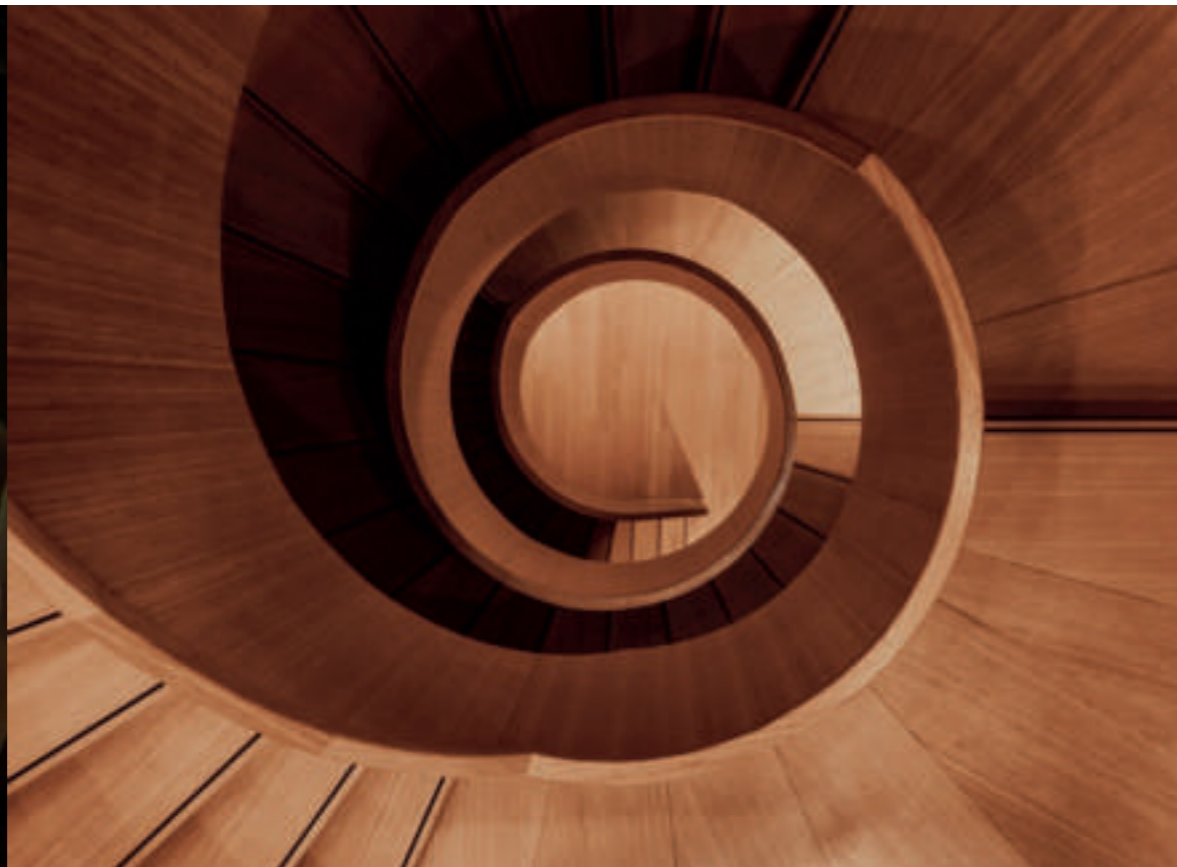



00154SX



00171DX

00175DX



00165

00171DX

00163DX

00175DX

00164SX



00153DX





00160



00160

903L

902L

Technical sheet



00163 DX
L.92cm P.80cm
H.78cm H.s.43cm
W.36 1/4" D.31 1/2"
H.30 3/4" S.h.17"



00165
L.88cm P.85cm
H.78cm H.s.43cm
W.34 3/4" D.33 1/2"
H.30 3/4" S.h.17"



00164 SX
L.92cm P.80cm
H.78cm H.s.43cm
W.36 1/4" D.31 1/2"
H.30 3/4" S.h.17"



00166 DX
L.92cm P.80cm
H.78cm H.s.43cm
W.36 1/4" D.31 1/2"
H.30 3/4" S.h.17"



00168
L.88cm P.85cm
H.78cm H.s.43cm
W.34 3/4" D.33 1/2"
H.30 3/4" S.h.17"



00167 SX
L.92cm P.80cm
H.78cm H.s.43cm
W.36 1/4" D.31 1/2"
H.30 3/4" S.h.17"



00153 DX
L.236cm P.106cm H.82cm H.s.43cm
W.93" D.41 3/4" H.32 1/4" S.h.17"



00154 SX
L.236cm P.106cm H.82cm H.s.43cm
W.93" D.41 3/4" H.32 1/4" S.h.17"



00155 DX
L.236cm P.106cm H.82cm H.s.43cm
W.93" D.41 3/4" H.32 1/4" S.h.17"



00156 SX
L.236cm P.106cm H.82cm H.s.43cm
W.93" D.41 3/4" H.32 1/4" S.h.17"



00159
L.180cm P.100cm H.90cm H.s.43cm
W.71" D.39 1/4" H.35 1/2" S.h.17"



00160
L.180cm P.100cm H.90cm H.s.43cm
W.71" D.39 1/4" H.35 1/2" S.h.17"



00171 DX
L.154cm P.68cm H.43cm
W.60 3/4" D.26 3/4" H.17"



00172 SX
L.154cm P.68cm H.43cm
W.60 3/4" D.26 3/4" H.17"



00173 DX
L.154cm P.68cm H.43cm
W.60 3/4" D.26 3/4" H.17"



00174 SX
L.154cm P.68cm H.43cm
W.60 3/4" D.26 3/4" H.17"



00175 DX
L.150cm P.62cm H.30cm
W.59" D.24 1/2" H.11 3/4"



00176 SX
L.150cm P.62cm H.30cm
W.59" D.24 1/2" H.11 3/4"



00177 DX
L.150cm P.62cm H.30cm
W.59" D.24 1/2" H.11 3/4"



00178 SX
L.150cm P.62cm H.30cm
W.59" D.24 1/2" H.11 3/4"



Cushions

design R&S Montbel



030060

L.60cm H.30cm

W.23 2/3" H.11 3/4"



040080

L.80cm H.40cm

W.31 1/2" H.15 3/4"



040040

L.40cm H.40cm

W.15 3/4" H.15 3/4"



050050

L.50cm H.50cm

W.19 2/3" H.19 2/3"



060060

L.60cm H.60cm

W.23 2/3" H.23 2/3"



070070

L.70cm H.70cm

W.27 1/2" H.27 1/2"



080080

L.80cm H.80cm

W.31 1/2" H.31 1/2"

Diadema

By Daniele Lo Scalzo Moscheri

Design essenziale e un'ampia gamma cromatica danno forma a infinite possibilità compositive.

A MINIMAL DESIGN AND A WIDE CHROMATIC RANGE
ALLOWS ENDLESS COMBINATIONS.





04021A

04010A

Forme semplici dalle linee morbide disegnano elementi con volumi e dimensioni differenti per una famiglia ricca di elementi con cui creare diversi schemi compositivi.

La famiglia si compone di pouf e tavolini di diverse dimensioni, disponibili sia con zoccolo che piedini in legno.

Vestiti da un'ampia gamma di tessuti e colori, lo rendono facilmente inseribile in qualunque contesto per una seduta occasionale e accessoria.

Simple shapes and soft lines outline elements with manifold volumes and sizes for a family rich in elements, with which several compositional schemes can be attained.

The family comprises poufs and small tables variously-sized, available both with a supporting base or wooden feet.

A wide range of fabrics and colours easily merge these seats into every setting for casual and accessory seating.

“Versatilità e colore per infinite combinazioni compositive”

“VERSATILITY AND COLOR FOR ENDLESS COMBINATIONS”

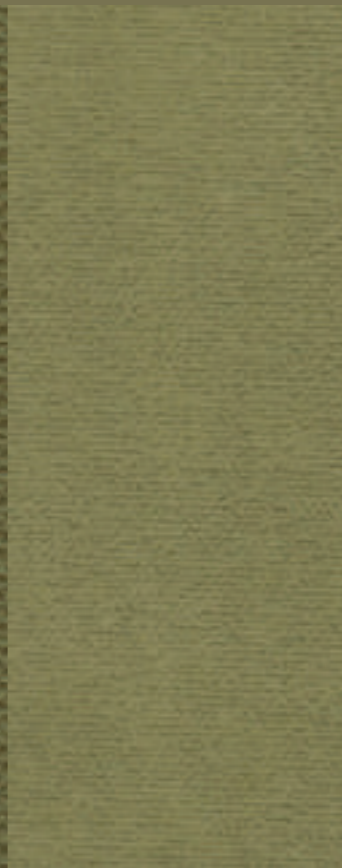
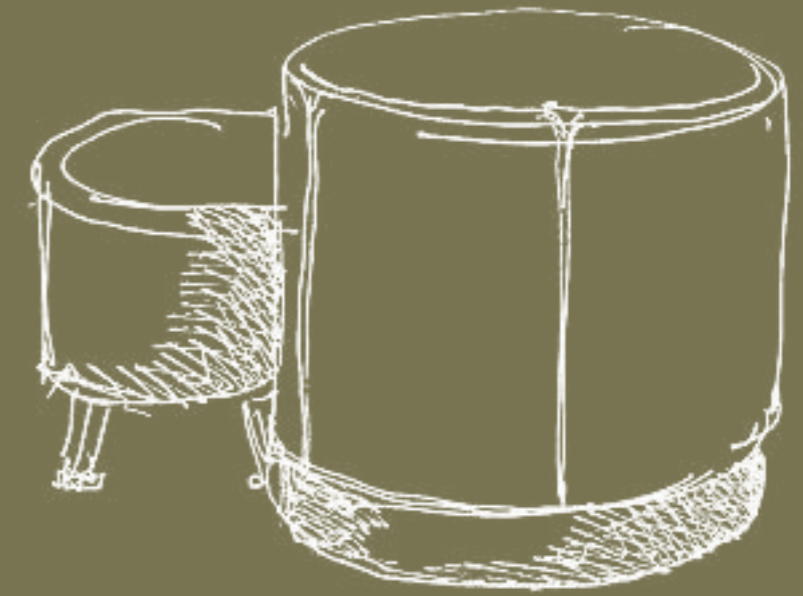



Technical sheet



04010

L.50cm P.50cm H.s.45,5cm
W.19 3/4" D.19 3/4" S.h.17,9"



04010A

L.50cm P.50cm H.s.48cm
W.19 3/4" D.19 3/4" S.h.19"



4011

L.50cm P.50cm H.s.45,5cm
W.19 3/4" D.19 3/4" S.h.17,9"



04011A

L.50cm P.50cm H.s.48cm
W.19 3/4" D.19 3/4" S.h.19"



04020

L.51cm P.50cm H.s.45,5cm
W.20" D.20" S.h.17,9"



04020A

L.51cm P.51cm H.s.48cm
W.20" D.20" S.h.19"



04021

L.51cm P.50cm H.s.45,5cm
W.20" D.20" S.h.17,9"



04021A

L.51cm P.51cm H.s.48cm
W.20" D.20" S.h.19"

Line

By Edi e Paolo Ciani

Collezione di tavolini caratterizzati dal gioco di linee e intrecci della loro struttura in metallo.

A COLLECTION OF SMALL TABLES FEATURING THE PLAY OF LINES
AND WEAVES OF THEIR METAL STRUCTURE .





La pulizia e il gioco di linee e intrecci della struttura in metallo caratterizzano questa collezione di tavolini disponibile in diverse dimensioni e altezze. Legni, marmi e laccati definiscono il top disponibile in diverse finiture.

The cleanness and interplay of lines and the twist of the metal structure characterise this collection of tables, available in several sizes and heights. Types of wood, marble and lacquers define the top, obtainable in several finishes.

Una struttura leggera dal sapore architettonico è l'espressione di un design essenziale e bilanciato.

A LIGHT STRUCTURE WITH AN ARCHITECTURAL FLAVOUR IS THE EXPRESSION OF AN ESSENTIAL, BALANCED DESIGN.

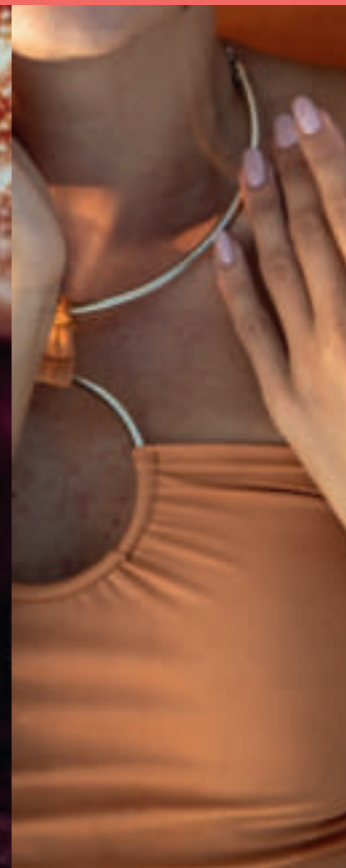
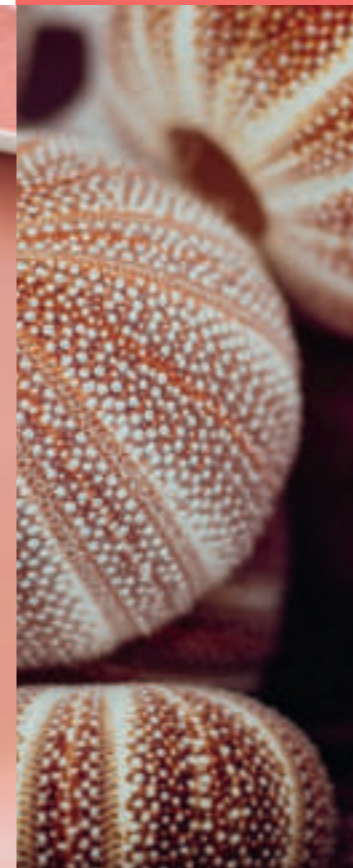



Technical sheet

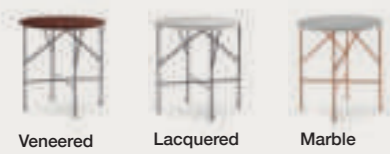

Veneered Lacquered Marble

701TD - 701L - 701M
L.55cm P.55cm H.55cm
W.21 2/3" D.21 2/3" H.21 2/3"

Cono

By Daniele Lo Scalzo Moscheri

Un gioco di volumi e proporzioni caratterizzano questa collezione di tavoli e tavolini che caratterizzano lo spazio con la loro forte personalità.

A PLAY OF VOLUMES AND PROPORTIONS CHARACTERIZE THIS COLLECTION OF TABLES AND SMALL TABLES, DISTINGUISHING THE SPACE WITH THEIR STRONG PERSONALITY.



MONTBEL . 406

Un segno pulito disegna perimetri tondi per un tavolo elegante e contemporaneo, facilmente collocabile in ambienti dalle diverse esigenze stilistiche e compositive. La base in metallo disponibile in due dimensioni è particolarmente versatile e personalizzabile con qualsiasi colorazione adattandosi così al materiale del top tondo o quadrato in diverse dimensioni.

A clean sign outlines round perimeters for a smart, contemporary table, easily fitted in to several locals, whatever your style and compositional requirements. Available in two dimensions, the especially versatile metal base can be custom-made with any colouring, thus adapting to the fabric of the round or square top, in various sizes.

CONO . 407

Equilibri importanti definiscono la pulizia formale di un tavolo dal carattere iconico.

MAJOR BALANCES DEFINE THE FORMAL NEATNESS OF A TABLE ENDOWED WITH AN ICONIC CHARACTER.

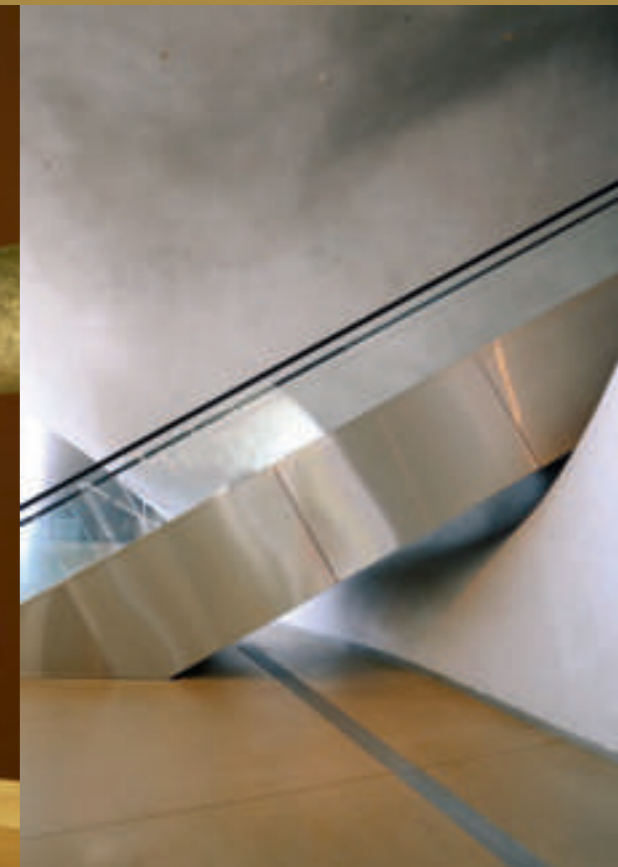
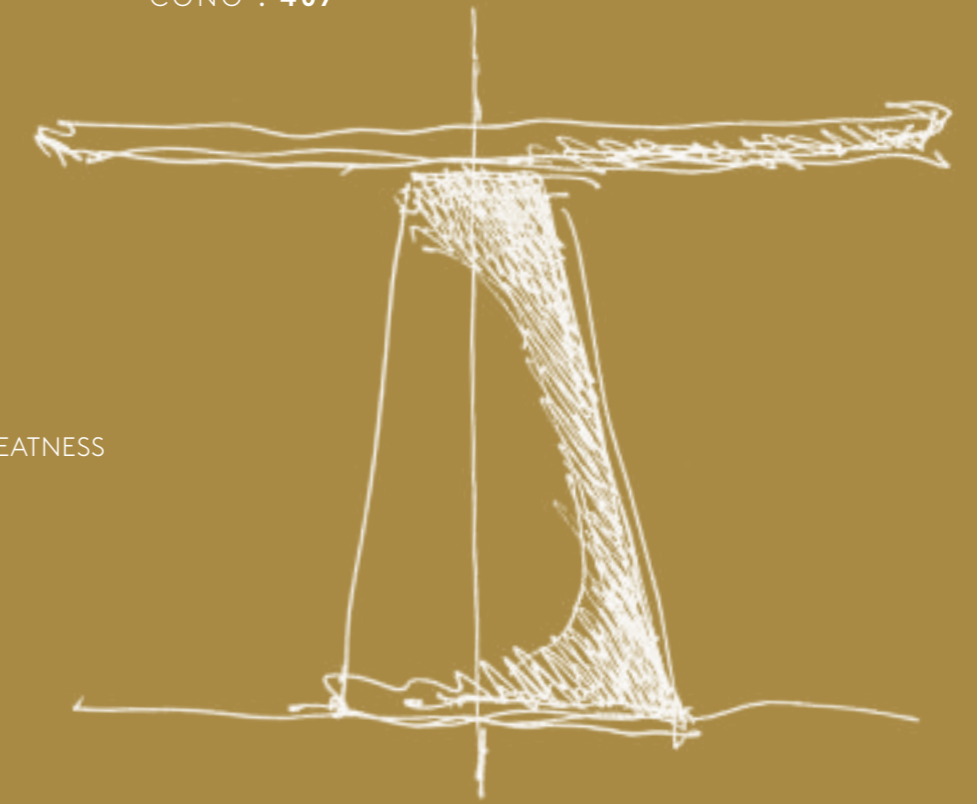



4001 + Q30



4004 + Q20

4003 + I25EF

4004 + Q20



4003 + I25EF

4004 + Q20



4004 + Q20

4001 + Q30



Technical sheet

Metal Base



4002
D.61cm H.72cm
top max diam. 120cm
W.24,02 H.28 1/4"
top max diam. 28,35



4001
D.41cm H.72cm
top max diam. 80cm
W.16,14 H.28,35
top max diam. 31 1/2"



4003
D.31cm H.55cm
Top Max diam. 70cm
W 12,2 H 21,65
Top max diam. 27,56



4004
D.31cm H.45
Top Max diam. 80cm
W. 12,2. H.17,72
Top max diam. 31,5

Top Options



Laminate



Veneered



Lacquered

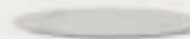

Grès

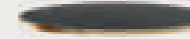

Grès + Metal Edge

Flen

By Daniele Lo Scalzo Moscheri

Sistema di tavoli sovrapponibili disponibili in tre diametri e tre altezze estremamente versatili grazie alla possibilità di personalizzare i top.

A SYSTEM OF SUPERIMPOSABLE TABLES COMING TO YOU IN THREE EXTREMELY VERSATILE DIAMETERS AND HEIGHTS, THANKS TO THE POSSIBILITY OF PERSONALISING THE TOPS.





905M

903TD



902L

902TD

Un segno pulito abbinato a perimetri tondi tutta la qualità di un manufatto in legno. Il perimetro della struttura è sagomato e determina leggerezza e carattere, le finiture delle strutture si abbinano alle diverse superfici dei piani. Marmi, laccati ed essenze rendono Flen un vero e proprio sistema di tavoli sovrapponibili disponibili con tre diametri e tre altezze.

A sleek mark matches rounded perimeters with all the quality of a wooden artefact. The perimeter of the structure is shaped, determining lightness and character; the structure finishes match with the various plane surfaces. Marbles, lacquers and essences make Flen an authentic system of superimposable tables, available in three diameters and just as many heights.

Geometrie classiche ed eleganti sono alla base di un design senza tempo.

CLASSIC, SMART GEOMETRIES ARE THE FOUNDATION OF A TIMELESS DESIGN.

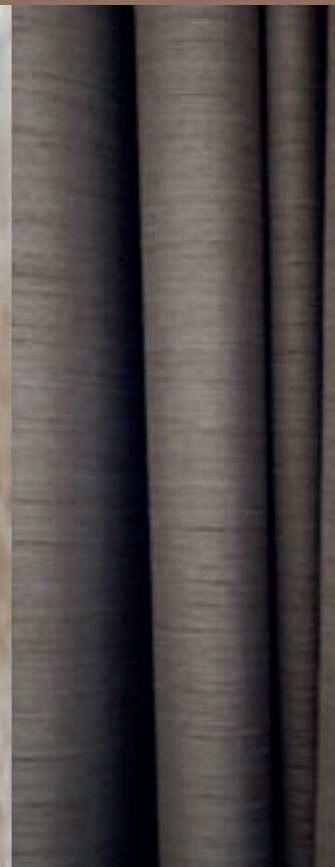
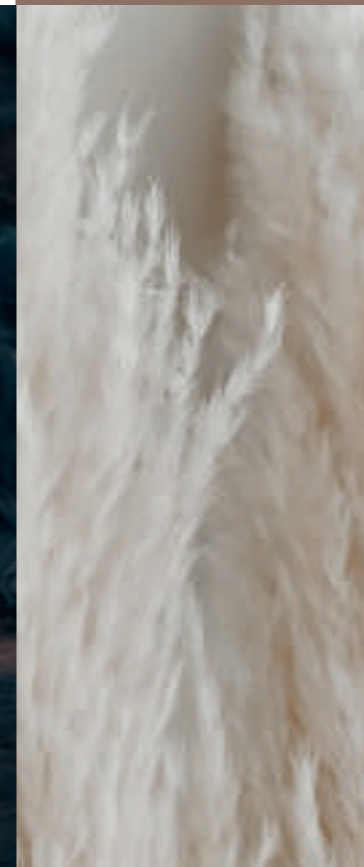
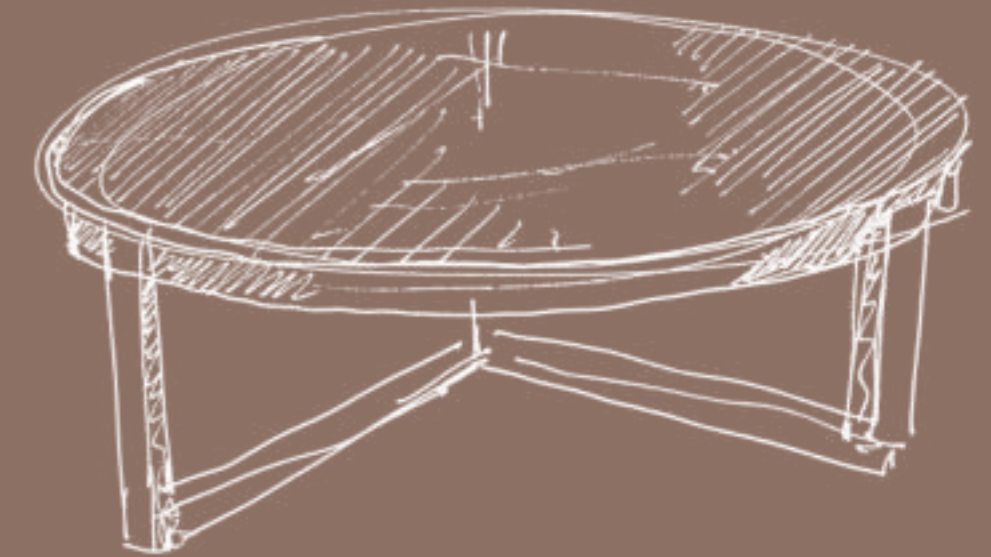



Technical sheet



Veneered Marble Lacquered

901TD-901M-901L

L.50cm P.50cm H.45cm
W.19 3/4" D.19 3/4" H.17 3/4"



Veneered Marble Lacquered

902TD-902M-902L

L.50cm P.50cm H.55cm
W.19 3/4" D.19 3/4" H.21 2/3"



Veneered Marble Lacquered

903TD-903M-903L

L.75cm P.75cm H.45cm
W.29 1/2" D.29 1/2" H.17 3/4"



Veneered Marble Lacquered

904TD-904M-904L

L.75cm P.75cm H.55cm
W.29 1/2" D.29 1/2" H.21 2/3"



Veneered Marble Lacquered

905TD-905M-905L

L.100cm P.100cm H.35cm
W.39 1/3" D.39 1/3" H.13 3/4"



Veneered Marble Lacquered

906TD-906M-906L

L.100cm P.100cm H.45cm
W.39 1/3" D.39 1/3" H.17 3/4"

credits

AD . Daniele Lo Scalzo Moscheri

Photo . emozioni.com

Fotolito . Luce Group

Stampa . sincromia.it

Stampa maggio 2023

international press office

Claim_Brand Industry

T. +39 0422 633865

sara.saltarelli@claim.it

Montbel Srl

Sales office

Via Braiduzza, 8

I-33048 San Giovanni al Natisone - Udine - Italy

T. +39 0432 743147 / 743233

Head office

Via D. Scuole, 30

I-33044 Manzano - Udine - Italy

T. +39 0432 750784

www.montbel.it - montbel@montbel.it

Tutte le dimensioni, pesi, caratteristiche e colori dei prodotti di questo catalogo sono indicativi e possono variare senza preavviso. Si prega di contattare il nostro ufficio vendite prima dell'ordine per informazioni aggiornate. Tutti i prodotti Montbel sono brevettati.

All sizes, weights, specifications and colours in this catalogue are for indication only and can vary without notice. Please contact our sales office prior to ordering for updated information. All Montbel's products are patent.

**The
Italian
Concept**

The Italian Concept is the network of brands specialized in the production of Made in Italy seats and furniture complements, able to offer high quality design solutions.

Discover more on : www.theitalianconcept.com

