

*L I V I N G
O B J E C T S*

*Recalling 2023
News 2024*

INDEX

/1

004 Company profile

/2

006 Summary

/3

008 Approaching sunset

/4

082 As light fades in

/5

118 Architecture of
emotions

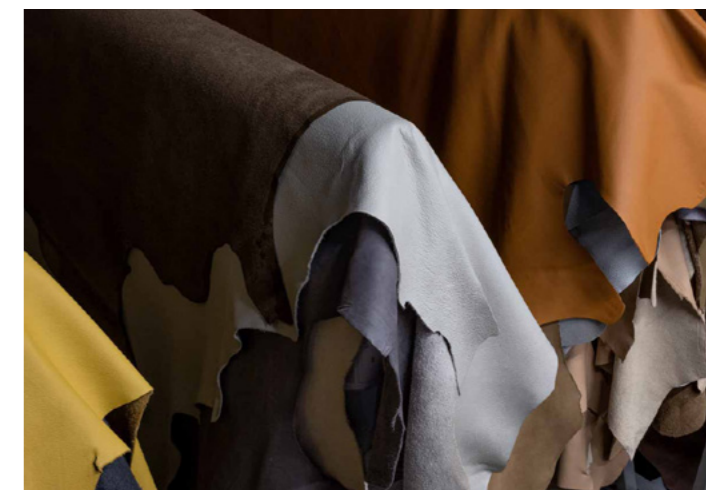

Potocco è un'azienda a conduzione familiare specializzata nella produzione di arredi indoor e outdoor per la casa e il contract. Fondata nel 1919, l'azienda si è evoluta trasformandosi in una vera e propria realtà industriale, emblema del Made in Italy. Oggi, Potocco è presente in tutto il mondo grazie a una solida rete di distributori con oltre 500 punti vendita e all'apertura della divisione Potocco USA. L'expertise produttiva del brand prende forma in un design contemporaneo ed essenziale, dando vita a un'estetica leggera, sofisticata, morbida ma al tempo stesso fortemente riconoscibile. Negli anni, Potocco ha chiamato ad interpretare la sua cifra stilistica progettisti italiani ed internazionali, tra cui Chiara Andreatti, Bernhardt&Vella, Mario Ferrarini, David Lopez Quincoces, Gabriele e Oscar Buratti, Marco Piva, Serena Confalonieri, Storagemilano, Toan Nguyen, Alexander Lorenz.

Potocco is a family-owned company specialized in the production of indoor and outdoor furniture for the home and contract sectors. Founded in 1919, the company has evolved into a true industrial reality, an emblem of Made in Italy. Today, Potocco is present all over the world thanks to a solid network of distributors with more than 500 points of sale and the opening of the Potocco USA division. The brand's manufacturing expertise takes shape in a contemporary and essential design, resulting in a light, sophisticated, soft yet strongly recognizable aesthetic. Over the years, Potocco has called on Italian and international designers to interpret its stylistic signature, including Chiara Andreatti, Bernhardt&Vella, Mario Ferrarini, David Lopez Quincoces, Gabriele and Oscar Buratti, Marco Piva, Serena Confalonieri, Storagemilano, Toan Nguyen, and Alexander Lorenz.

Recalling 2023

- 032 CONCHA
loung armchair
- 130 CUT
outdoor dining chairs,
outdoor stools
- 036 GRAPHIC
indoor dining tables,
indoor coffee tables,
indoor bench, writing desk
- 058 GRAPHIC
outdoor dining tables,
outdoor coffee tables,
outdoor bench
- 078 HIRU
dining chair,
dining armchair,
stools
- 010 JADE
modular sofa, lounge,
loung armchair, coffee tables
- 084 MINIMA
dining chairs

Novelties 2024

NEW FINISHES

- 144 HISHI
indoor & outdoor coffee tables
- 110 SEN
cabinet
- 148 SOPHIE
dining table

NEWS

- 124 CUT
indoor dining chairs,
indoor stools,
outdoor rocking loung armchair
- 106 DOUBLE L GLAZE NEW COLLECTION
coffee tables
- 036 GRAPHIC
indoor modular sofa
- 058 GRAPHIC
outdoor modular sofa
- 114 HELVETICA NEW COLLECTION
dining chairs
- 010 JADE
loung armchair,
dining armchair
- 084 MINIMA
dining armchairs,
stools
- 098 SYN NEW COLLECTION
dining tables
- 140 TROUSSE NEW COLLECTION
dining chair
- 120 VELIS CANE
dining armchairs

—— Il cielo limpido del giorno cede il passo alle sfumature tenui della sera, la materia si colora dei toni caldi del tramonto. Lentamente sagome e profili si fondono con l'orizzonte trasformandosi in un corpo unico dai contorni sbiaditi, aspettando l'alba di un nuovo giorno.

The clear daylight surrenders to the soft shades of the evening, the matter is infused with the warm tones of sunset. Silhouettes and profiles slowly merge with the horizon, shaping into a single body where outlines are faded, while waiting for a new dawn.

Approaching sunset

Chapter I



Jade family / Concha lounge armchair / Graphic family / Hiru family

JADE

*Lounge armchair, Lounge,
Modular sofa, Coffee tables,
Dining armchair*

La collezione Jade - composta da un sistema di divani, poltrone e tavolini - si arricchisce con la nuova poltrona con braccioli e la poltroncina dining, caratterizzate da profili sinuosi e forme morbide e organiche che rimandano alla natura. Tutti gli elementi della famiglia Jade possono essere utilizzati singolarmente o combinati creando isole di comfort sempre diverse e fluide che si adattano agli spazi e alle situazioni, dall'intimità degli ambienti domestici ai grandi progetti contract.

The Jade collection - composed of a system of sofas, armchairs, and coffee tables - is enriched with the new armchair with armrests and the dining armchair, characterized by sinuous profiles and soft, organic shapes that recall nature.

All elements of the Jade family can be used individually or combined, creating ever-changing and fluid islands of comfort that adapt to spaces and situations, from the intimacy of domestic settings to large contract projects.





JADE modular sofa 953/D, uph. Dolly Avorio Q2B. Dolly Mattone Q2D pillows. Celia Blulette D7M pillows.
JADE coffee table 953/TBO, Biscuit ash wood base, Fior di Pesco Carnico marble top.
GRAPHIC coffee tables 955/TBC-40 - 955/TBC-60 - 955/TBC-80, Anthracite base, Biscuit ash wood top.



JADE modular sofa 953/D, uph. Dolly Avorio Q2B. Dolly Mattone Q2D pillows.
 JADE coffee table 953/TBT, Biscuit ash wood base, Fior di Pesco Carnico marble top.
 GRAPHIC coffee table 955/TBC-80, Anthracite base, Olive green ash wood top.
 GAMBIT rug, 970/R1 - 970/R2 Butter.





JADE lounge 953/L, uph. Cortina Terracotta A9I. **NEWS 2024**
GRAPHIC coffee table, 955/TBC-60, Anthracite base, Biscuit ash wood top.
GAMBIT rug, 970/R2 Butter.

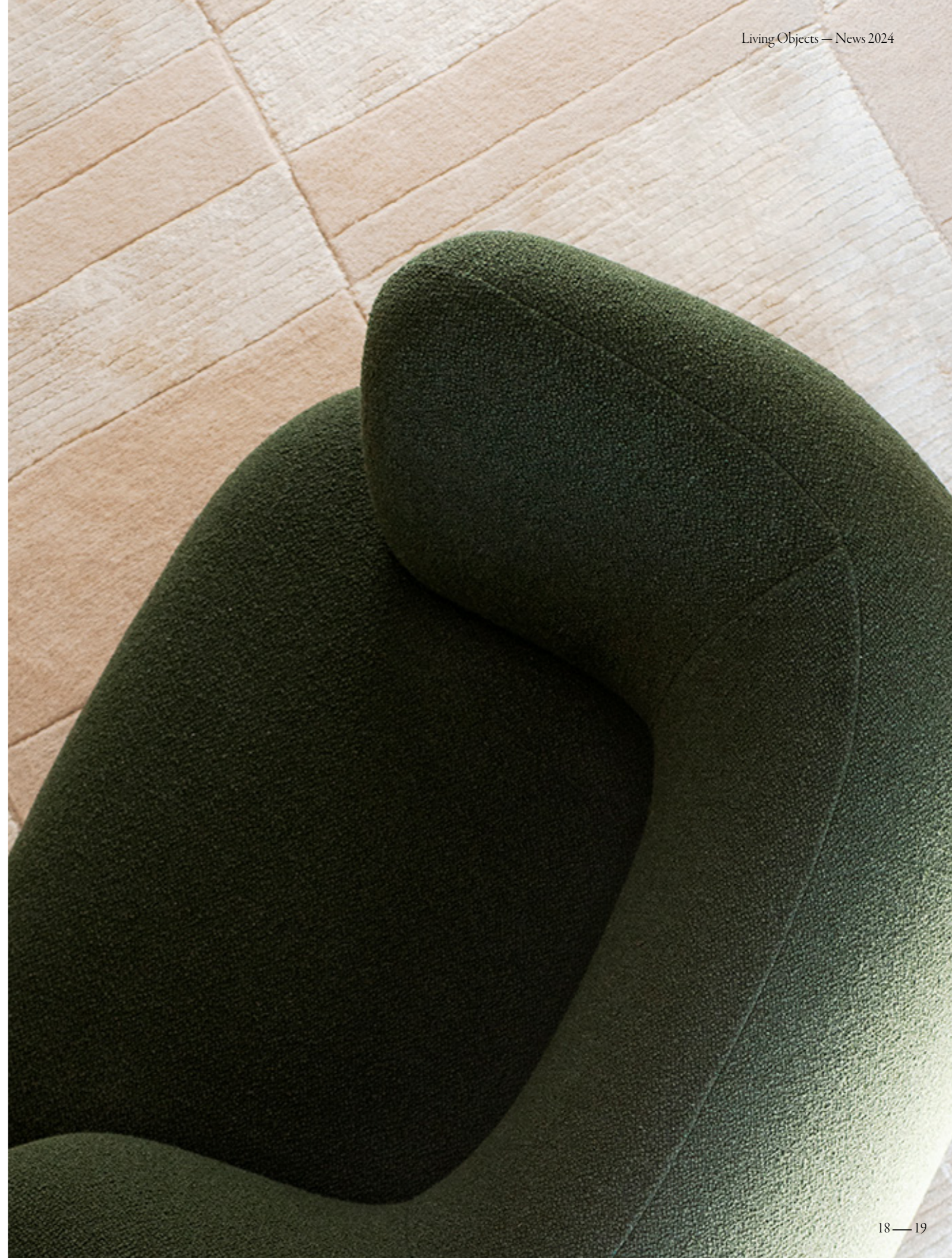

JADE lounge armchair 953/PL, uph. Dolly Bosco Q2G. NEWS 2024
GRAPHIC coffee table 955/TBC-60, Anthracite base, Cherry ash wood top.
GAMBIT rug, 970/R2 Butter.



JADE coffee table 953/TBT, Biscuit ash wood base, Fior di Pesco Carnico marble top.
GRAPHIC side table 955/TBC-40, Aval base, Biscuit ash wood top.
GAMBIT rug, 970/R2 Butter.



JADE coffee table 953/TBO, Biscuit ash wood base,
Travertino Romano marble top.



NEWS 2024 JADE dining armchair 953/P, uph. Dolly Grigio Q2E.
JADE dining armchair 953/P, uph. Bess Cammello 10.

JADE

Design Hanne Willmann

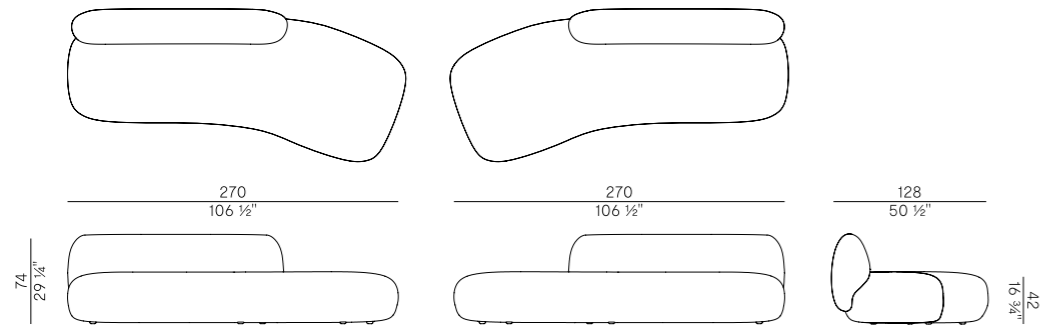

953/RE-DX, 953/RE-SX

modulo recamiere destro e sinistro \ right and left recamiere unit

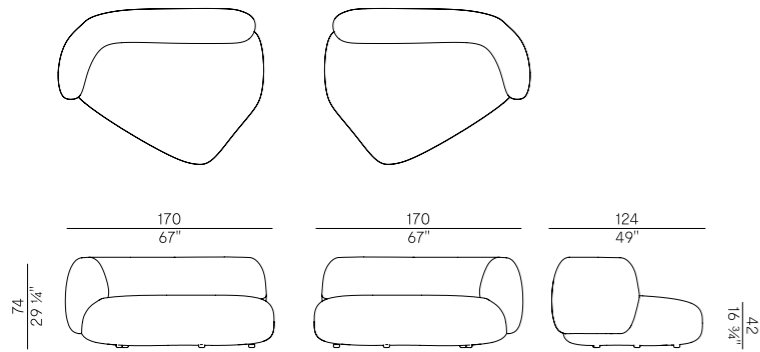

953/OC-DX, 953/OC-SX

modulo off-shape corner destro e sinistro \ right and left off-shape corner unit

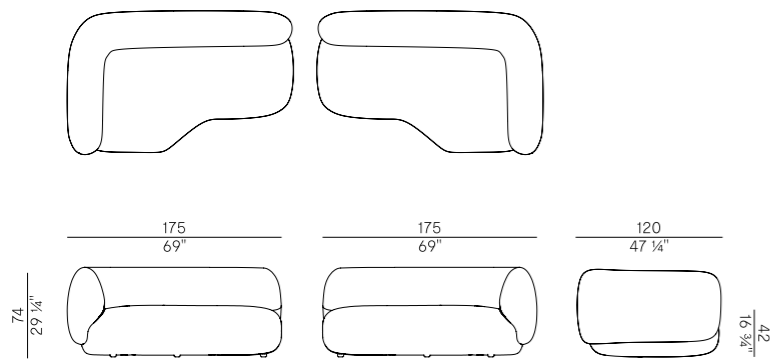

953/CC-DX, 953/CC-SX

modulo combi corner destro e sinistro \ right and left combi corner unit

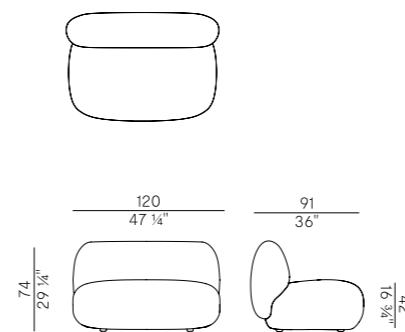

953/DM

modulo intermedio \ intermediate unit

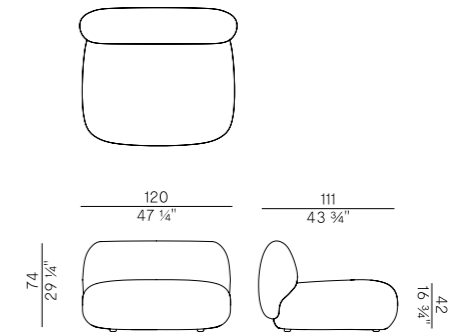

953/DML

modulo intermedio large \ large intermediate unit

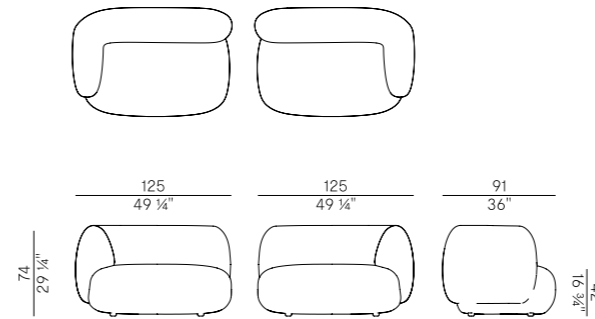

953/DT-DX, 953/DT-SX

modulo corner destro e sinistro \ right and left corner unit

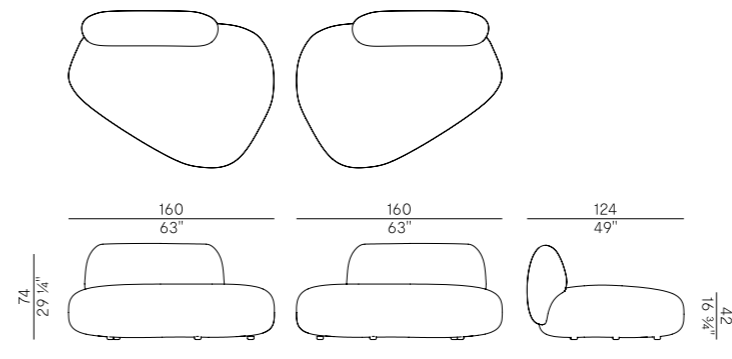

953/OCL-DX, 953/OCL-SX

modulo off-shape chaise longue destro e sinistro \ right and left off-shape chaise longue unit

JADE

Design Hanne Willmann

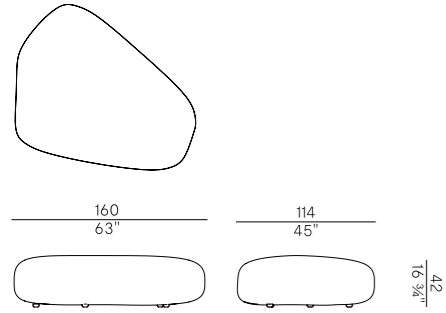

953/OL

modulo off-shape pouf \ off-shape pouf unit

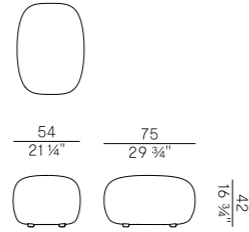

953/O

modulo off-shape pouf small \ off-shape small pouf unit

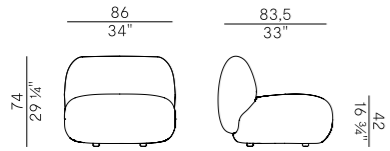

953/L

lounge \ lounge

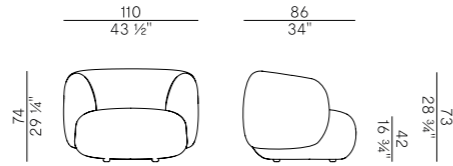

953/PL

poltrona lounge \ lounge armchair

ESEMPI DI COMPOSIZIONE \ COMPOSITION EXAMPLES

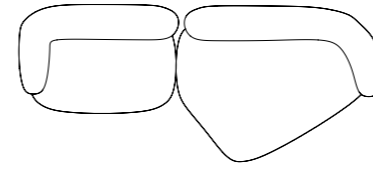

modulo corner destro, modulo off-shape corner sinistro \
right corner unit, left off-shape corner unit

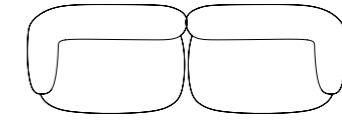

modulo corner destro, modulo corner sinistro \
right corner unit, left corner unit

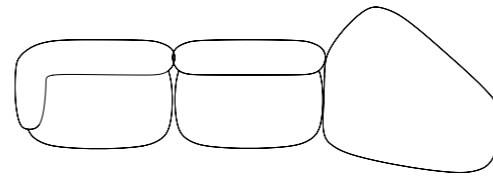

modulo corner destro, modulo intermedio, modulo off-shape pouf \
right corner unit, intermediate unit, off-shape pouf unit

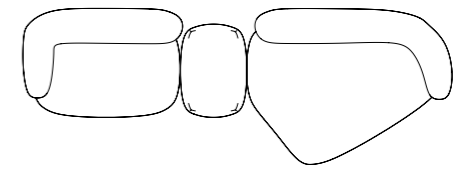

modulo corner destro, modulo off-shape pouf small, modulo off-shape corner sinistro \
right corner unit, off-shape small pouf unit, left off-shape corner unit

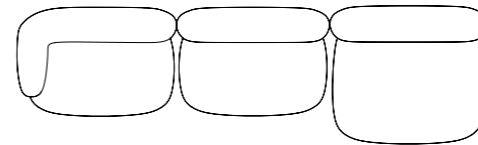

modulo corner destro, modulo intermedio, modulo intermedio large \
right corner unit, intermediate unit, large intermediate unit

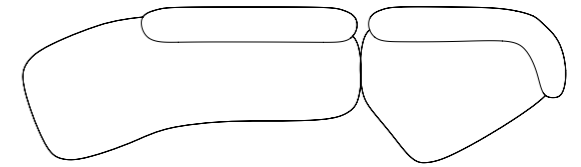

modulo recamiere sinistro, modulo off-shape corner sinistro \
right and left recliner unit, left off-shape corner unit

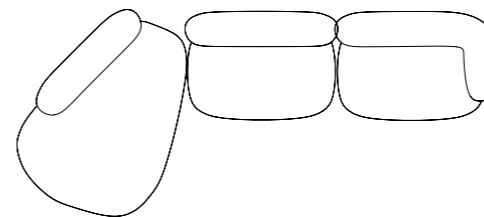

modulo off-shape chaise longue destro, modulo intermedio, modulo corner sinistro \
right off-shape chaise longue unit, intermediate unit, left corner unit

JADE

Design Hanne Willmann

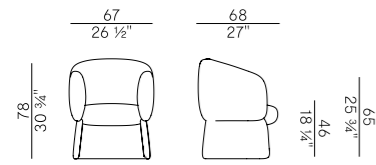

953/P

poltroncina dining \ dining armchair

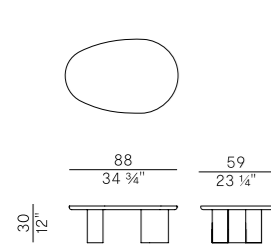

953/TBO

tavolino ovale \ oval coffee table

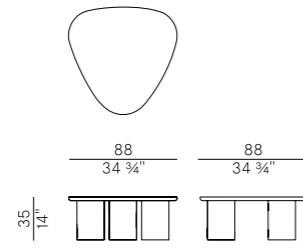

953/TBT

tavolino triangolare \ triangular coffee table

FINITURE TAVOLINI / COFFEE TABLES FINISHES

BASE IN FRASSINO

ASH BASE

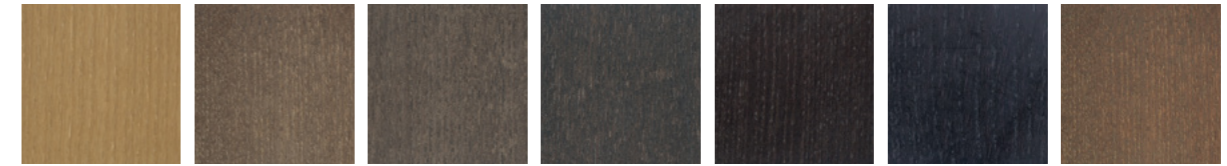

SG

Beige \ Beige

SC

Biscotto \ Biscuit

HJ

Moka \ Moka

HK

Grigio plumbeo \ Dark grey

HL

Wengé \ Wengé

HP

Carbone \ Carbon

SN

Noce \ Walnut

PIANO IN MARMO

MARBLE TOP

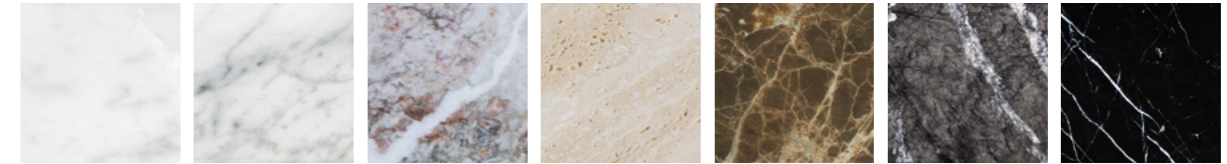

Bianco Carrara lucido \ Glossy White Carrara

Bianco Carrara opaco \ Matt White Carrara

Fior di pesco Carnico \ Fior di pesco Carnico

Travertino Romano \ Travertino Romano

Dark Emperador \ Dark Emperador

Grigio Carnico \ Grigio Carnico

Nero Marquinia \ Nero Marquinia

TESSUTI DISPONIBILI PER L'IMBOTTITURA: BESS (CAT. 2), CORTINA (CAT. 3), DOLLY (CAT. 4)
 FABRICS AVAILABLE FOR UPHOLSTERY: BESS (CAT. 2), CORTINA (CAT. 3), DOLLY (CAT. 4)

CONCHA

Lounge armchair

Elemento distintivo della collezione Concha è l'avvolgente schienale imbottito e leggermente inclinato, la cui forma a conchiglia ne ha ispirato il nome; le gambe sono in massello di rovere. Declinata in sedia con o senza braccioli, sgabello e poltrona lounge, Concha presenta linee essenziali che lo rendono un prodotto adatto ad ambienti domestici e spazi contract, all'insegna della massima versatilità.

The distinctive element of the Concha collection, enriched by the new two-height stool, is the enveloping padded and slightly inclined backrest, whose seashell shape inspired its name. With legs in solid oak wood, Concha has essential lines that make it a suitable product for domestic environments and contract spaces, in the name of maximum versatility.



CONCHA

Design Stephan Veit

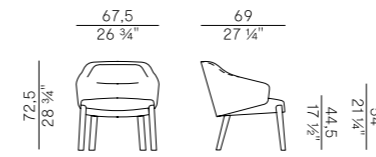

905/PL

poltrona lounge \ lounge armchair

FINITURE / FINISHES

STRUTTURA IN ROVERE
OAK FRAME



CONCHA lounge armchair 905/PL,
Dark grey oak wood frame, uph. Dafne Panna B2B.

GRAPHIC

/Indoor

*Dining tables, Coffee tables, Bench,
Writing desk, Modular sofa*

La collezione Graphic, minimale e lineare e composta inizialmente da tavoli, panca, scrittoio e tavolini accessori, si amplia introducendo un ambizioso progetto di seduta modulare. Il divano per indoor, composto da elementi imbottiti e tavolini fianco divano, è caratterizzato da una commistione di materiali originali e raffinati: legno di frassino, metallo e marmo.

The minimal and linear Graphic collection, initially composed of tables, bench, writing desk and side tables, expands by introducing an ambitious modular seating project. The indoor sofa, composed of upholstered elements and sofa side table, features a mixture of original and refined materials: ash wood, metal, and marble.



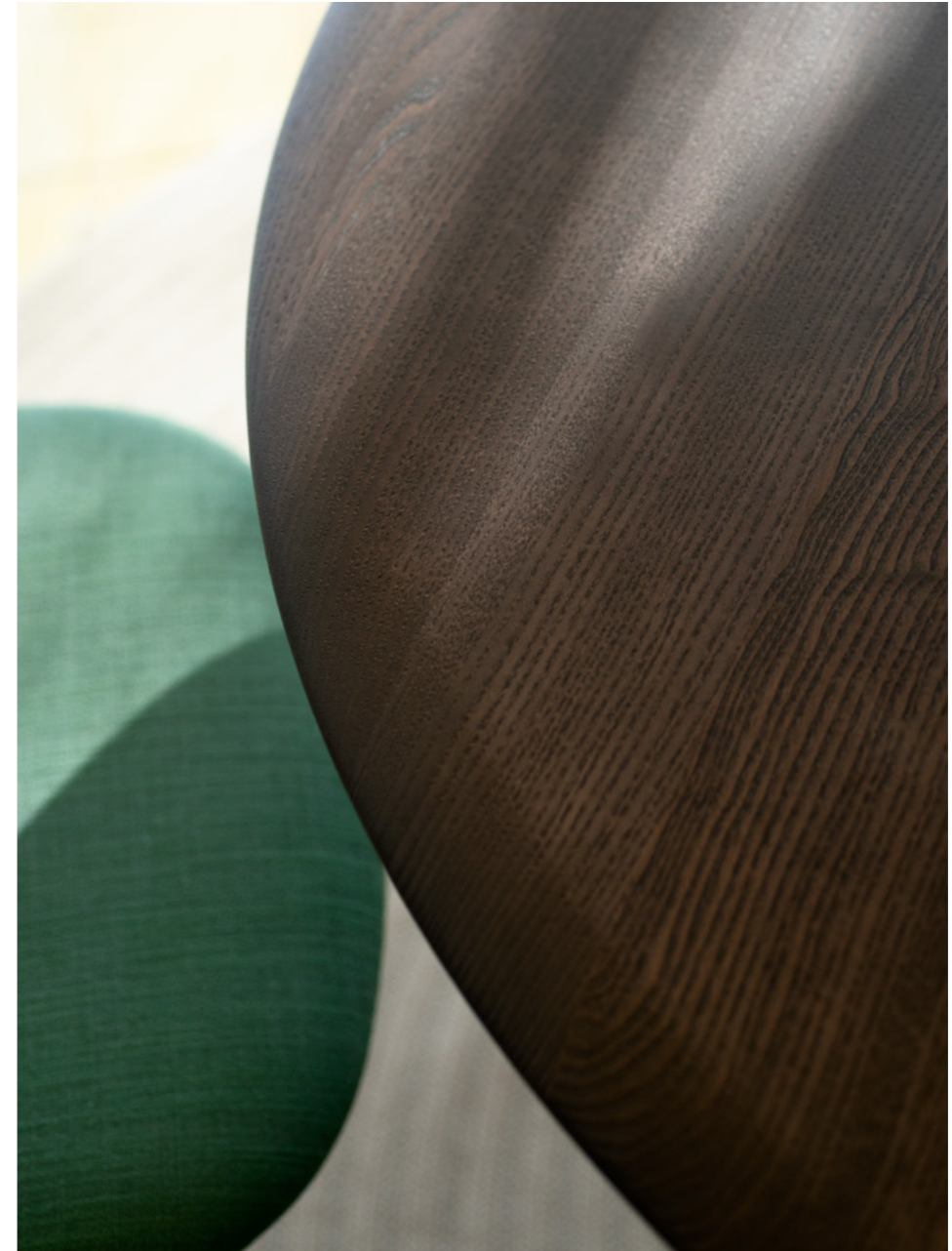

GRAPHIC dining table 955/TGC, Anthracite base, Moka ash wood top.
KEEL LIGHT dining chairs 922/MB, Anthracite base, Moka ash wood backrest,
uph. Baldo Bosco B7J.
CLUE rug 971/C Beige.





GRAPHIC dining table 955/TR, Anthracite base, Moka ash wood top.
 GRAPHIC bench 955/O, Anthracite base, Moka ash wood top.
 LÉNA dining chairs and dining armchairs 903 - 903/P, Moka ash wood frame, uph. Dafne Mattone B2D.



GRAPHIC dining table 955/TSGC, NEWS 2024
 Anthracite base, Moka ash wood top.



GRAPHIC bar table 955/TAC, Anthracite base, Moka ash wood top.
KEEL LIGHT barstools 922/AMB, Moka ash wood backrest,
Anthracite frame, uph. Galea Dattero C4V.





GRAPHIC modular sofa 955/D, Aval base, Biscuit ash wood frame, NEWS 2024
Black blurred glass, uph. Dolly Bosco Q2G.



GRAPHIC writing desk 955/SCR,
Aval base, Moka ash wood top.





GRAPHIC side table 955/TBC-40, Aval base, Biscuit ash wood top.
GRAPHIC coffee table 955/TBC-60, Aval base, Fior di Pesco Carnico marble top.
GRAPHIC coffee table 955/TBC-80, Aval base, Bianco Carrara matt marble top.



GRAPHIC side table 955/TBC-40, Aval base, Bluette ash wood top.
GRAPHIC coffee table 955/TBC-60, Aval base, Cherry ash wood top.
GRAPHIC coffee table 955/TBC-80, Aval base, Olive green ash wood top.



GRAPHIC

Design M+V

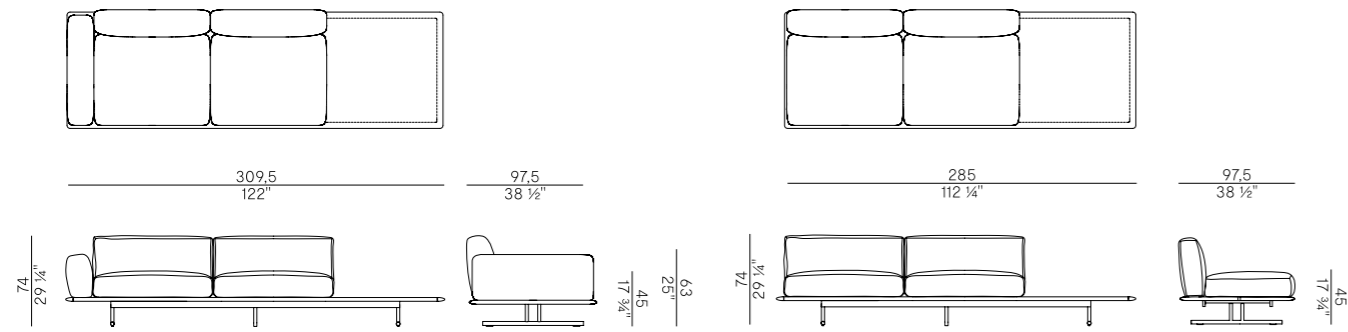

955/D-307
divano componibile \ modular sofa

955/D-285
divano componibile \ modular sofa

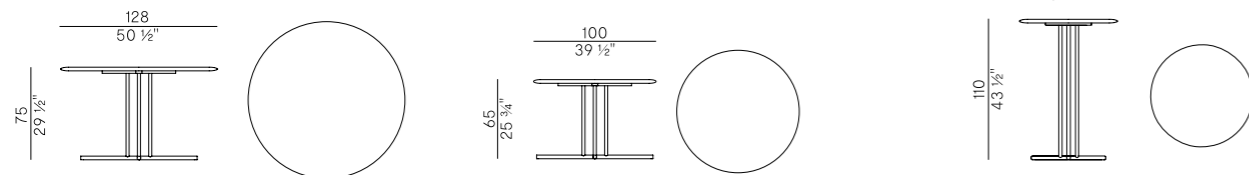

955/TGC
tavolo \ table

955/TSGC
tavolo \ table

955/TAC
tavolo alto \ high table

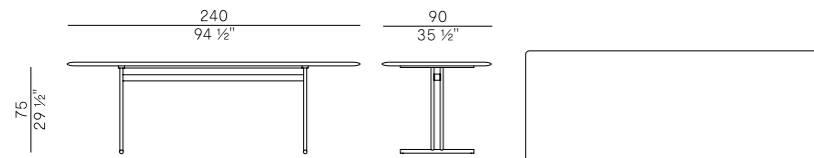

955/TR
tavolo \ table



955/SCR
scrittoio \ writing desk

955/O
panca \ bench

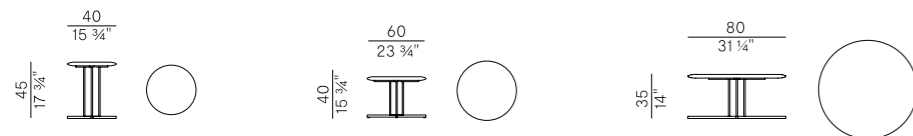

955/TBC-40
tavolino \ coffee table

955/TBC-60
tavolino \ coffee table

955/TBC-80
tavolino \ coffee table

FINITURE INDOOR / INDOOR FINISHES

BASE IN METALLO VERNICIATO
LACQUERED METAL BASE

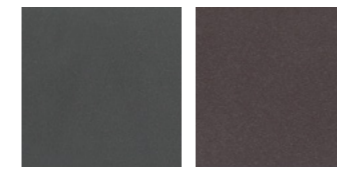

Antracite goffiato \ Anthracite embossed
Aval goffiato \ Aval embossed

PIANO IN FRASSINO
ASH TOP

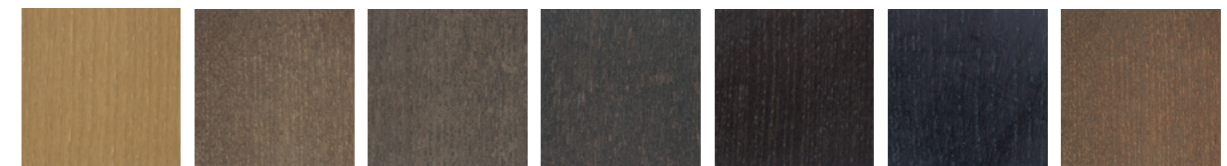

SG Beige \ Beige
SC Biscotto \ Biscuit
HJ Moka \ Moka
HK Grigio plumbeo \ Dark grey
HL Wengé \ Wengé
HP Carbone \ Carbon
SN Noce \ Walnut

PIANO IN FRASSINO TINTO COLORI SPECIALI (955/TBC-40, 955/TBC-60, 955/TBC-80)
ASH WOOD TOP STAINED SPECIAL COLORS

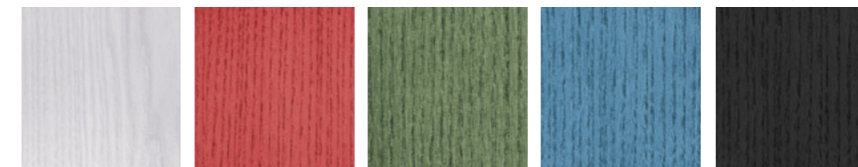

White
Cherry
Olive green
Bluette
Black

PIANO IN MARMO (955/TBC-40, 955/TBC-60, 955/TBC-80, 955/D)
MARBLE TOP

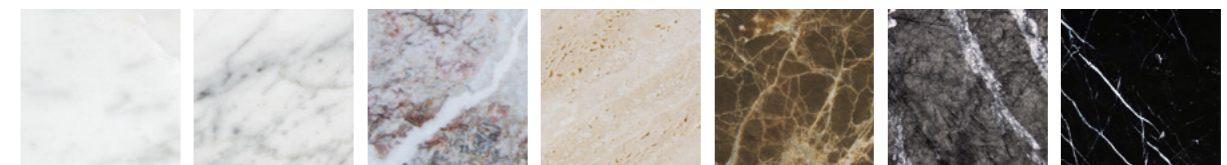

Bianco Carrara lucido \ Glossy White Carrara
Bianco Carrara opaco \ Matt White Carrara
Fior di pesco Carnico \ Fior di pesco Carnico
Travertino Romano \ Travertino Romano
Dark Emperador \ Dark Emperador
Grigio Carnico \ Grigio Carnico
Nero Marquina \ Nero Marquina

PIANO IN VETRO MOSSO (955/D)
BLURRED GLASS TOP

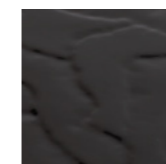

Nero \ Black

GRAPHIC

/Outdoor

*Dining tables, Coffee tables,
Bench, Modular sofa*

La collezione Graphic per outdoor, dal carattere leggero ed essenziale, lega insieme materiali differenti come il legno di frassino waterproof, metallo e pietra naturale o gres porcellanato. Il divano, dalle linee pulite e dalle forme arrotondate che invitano al relax, è progettato per offrire un comfort d'eccezione grazie alle sue sedute, ampie e profonde, sorrette da un'elegante struttura sottile.

The Graphic outdoor collection, with its light and essential character, ties together different materials such as waterproof ash wood, metal and natural stone or laminated porcelain. The sofa, with clean lines and rounded shapes that evoke relaxation, is designed to offer exceptional comfort thanks to its wide and deep seats supported by an elegant thin frame.







GRAPHIC rectangular dining table 955/TR-OUT, Anthracite base, Anthracite hpl top.
 GRAPHIC bench 955/O-OUT, Anthracite base, Anthracite hpl top.
 KEEL dining chairs 922/OUT, Iroko wood backrest, Anthracite frame, uph. Summer Alga B6K.



GRAPHIC circular dining table 955/TGC-OUT, Anthracite base, Anthracite hpl top.
OLA stackable dining chair 923, Anthracite frame, Fly grey ribbon S4E, uph. Sunset Light blue T1E.
CLUE circular outdoor rug 971/C Beige.





GRAPHIC circular dining table 955/TGC-OUT, **NEW FINISH**
Aval base, Iroko wood top.



GRAPHIC coffee tables 955/TBC-60-OUT - 955/TBC-40-OUT, **NEW FINISH**
Aval base, Iroko wood top.



GRAPHIC bar table 955/TAC-OUT, Anthracite base, Anthracite hpl top.
KEEL barstools 922/A-OUT, Iroko wood backrest, Anthracite frame, uph. Summer Corniola B6l.



GRAPHIC coffee table 955/TBC-80-OUT, Anthracite base, Light grey natural stone top.
CUT bergère 910/PLR, Anthracite frame, "Gassa" beige ribbon A7A, uph. Summer Red Blue B6M.



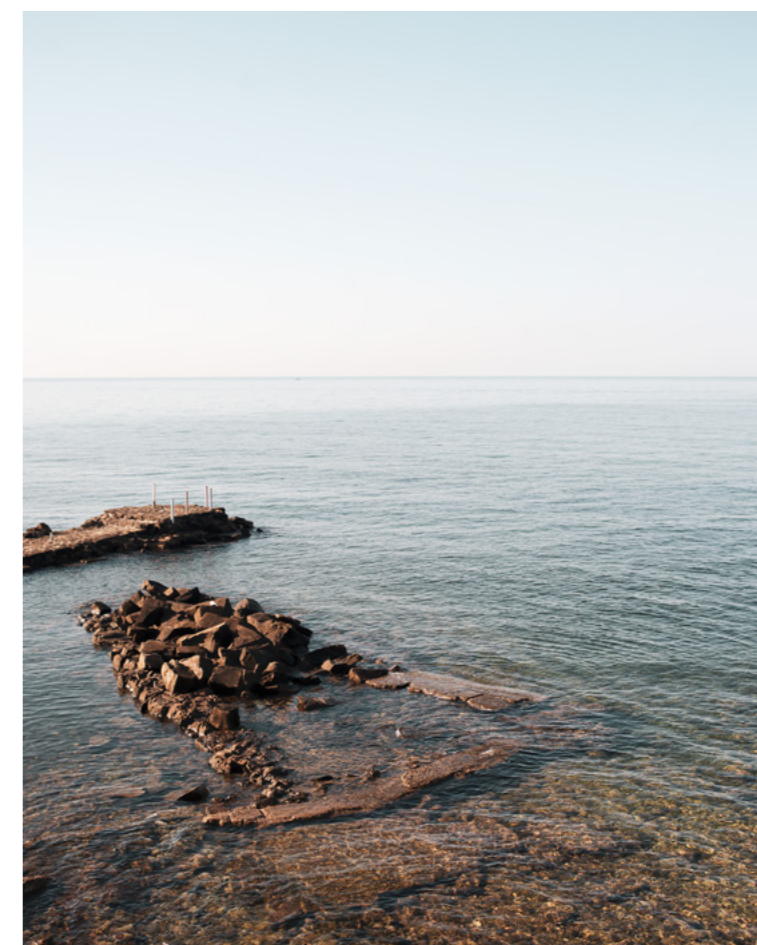

GRAPHIC coffee table 955/TBC-60-OUT, Anthracite base, Anthracite hpl top.
GRAPHIC side table 955/TBC-40-OUT, Anthracite base, Light grey natural stone top.



GRAPHIC modular sofa 955/D, Anthracite base, **NEWS 2024**
Waterproof ash wood frame, uph. Summer Cipria B6D.

GRAPHIC (outdoor)

Design M+V

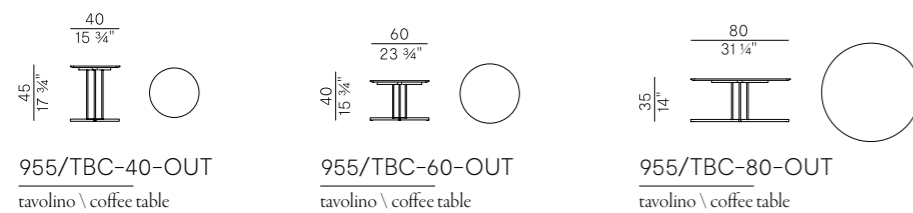
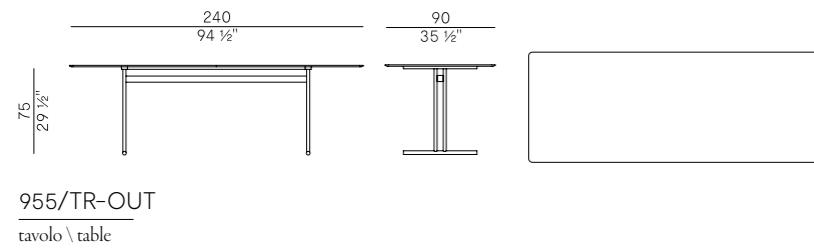
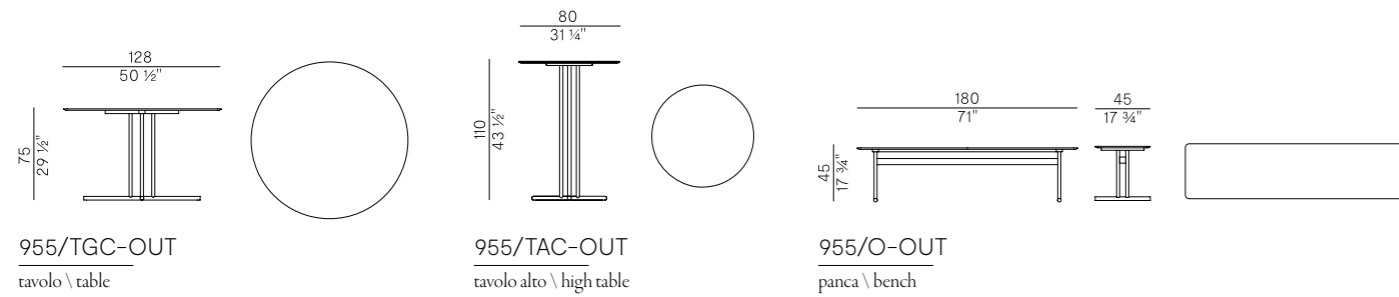
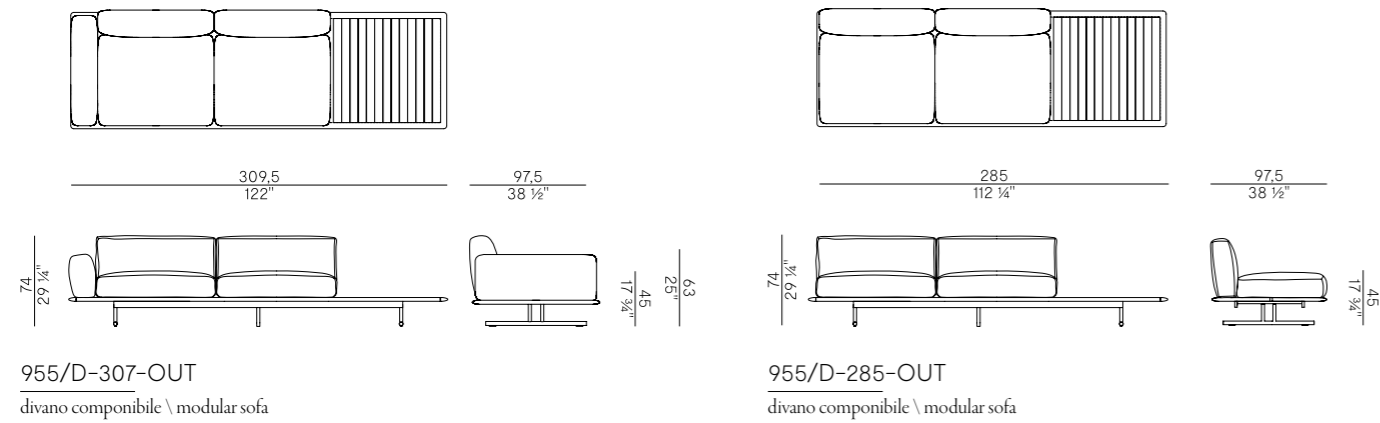

FINITURE OUTDOOR / OUTDOOR FINISHES

BASE IN METALLO VERNICIATO LACQUERED METAL BASE

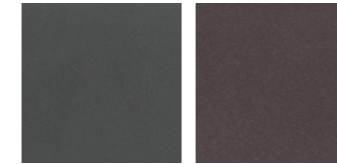

Antracite goffrato \ Anthracite embossed
Aval goffrato \ Aval embossed

PIANO (955/TGC-OUT, 955/TR-OUT, 955/TAC-OUT, 955/TBC-40-OUT, 955/TBC-60-OUT, 955/TBC-80-OUT) TOP

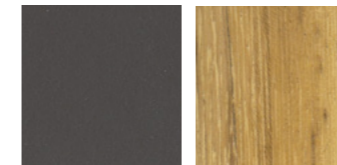

HPL Antracite \ Anthracite
EU Iroko \ Iroko

PIANO IN PIETRA (955/TBC-40-OUT, 955/TBC-60-OUT, 955/TBC-80-OUT) STONE TOP

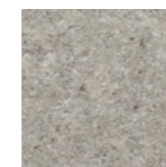

Pietra naturale light grey \ Light grey natural stone

CORNICE IN FRASSINO WATERPROOF (955/D-OUT) WATERPROOF ASH FRAME

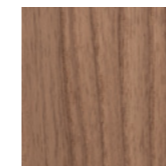

SU Frassino waterproof (dogato) \ Waterproof ash

PIANO TAVOLO (955/D-OUT) TABLE TOP

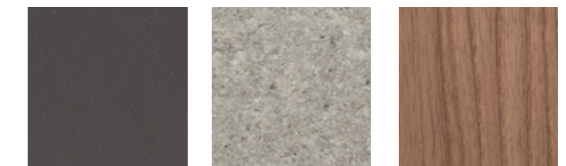

HPL Antracite \ Anthracite
Pietra naturale light grey \ Light grey natural stone
SU Frassino waterproof (dogato) \ Waterproof ash (slatted top)

HIRU

*Barstool, Counter stool,
Dining chair, Dining armchair*

La famiglia di sedute Hiru è formata da sedia, poltroncina e sgabello caratterizzate da gambe elicoidali e superfici non planari. Un rapporto vicendevole dove il legno diventa la struttura su cui si sviluppa il rivestimento, visibile da ogni angolazione della seduta, mostrando la sapiente capacità dell'azienda di lavorare il legno come materia viva. In occasione del Salone del Mobile.Milano 2024, Hiru viene presentata in una nuova versione bicolore che prevede la coesistenza di due differenti tessuti nel fronte e nel retro della seduta. The Hiru seating family consists of dining chair and armchair and stool characterized by helical legs and non-planar surfaces. A reciprocal relationship where the wood becomes the structure on which the upholstery is developed, visible from every angle of the seat, showing the company's expert capacity to work wood as a living material. On the Salone del Mobile. Milano 2024, Hiru is presented in a new two-tone version that involves the coexistence of two different fabrics in the front and back of the seat.



HIRU barstool 947/A, Moka ash wood frame, uph. Galea Tortora C4U.
GRAPHIC bar table 955/TAC, Anthracite base, Moka ash wood top.



HIRU

Design Mario Ferrarini

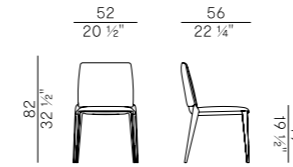

947
sedia dining \ dining chair

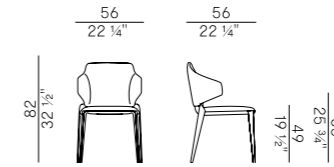

947/P
poltroncina dining \ dining armchair

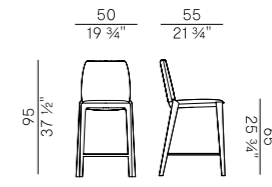

947/S
sgabello basso \ counterstool

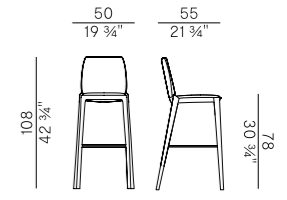

947/A
sgabello alto \ barstool

FINITURE / FINISHES

STRUTTURA IN FRASSINO
ASH FRAME



SG
Beige \ Beige

SC
Biscotto \ Biscuit

HJ
Moka \ Moka

HK
Grigio plumbeo \ Dark grey

HL
Wengé \ Wengé

HP
Carbone \ Carbon

SN
Noce \ Walnut



HIRU dining chair and dining armchair 947 - 947/P,
Dark grey ash wood frame, uph. Saia Blu Ginori - Veloute Blu notte.

— Una ricercata sobrietà fatta di materiali caldi, avvolgenti, confortevoli.
Un'estetica senza tempo da vivere nell'armonia di spazi in continuo mutamento, con giochi di luce e ombre che seguono l'alternarsi perpetuo del giorno e della sera.

A refined sobriety made of warm, enveloping, comfortable materials. A timeless aesthetic to live in the constant changing spaces' harmony, with plays of light and shadows that follow the perpetual alternation of day and evening.

As light
fades in



Chapter II

Minima family / Hyper dining tables / Double L coffee tables / Sen sideboard / Helvetica dining chairs

MINIMA

*Stackable dining chairs,
Stackable dining armchairs,
Barstools, Counter stools*

Minima è una collezione di sedute interamente in legno che si arricchisce, in occasione del Salone del Mobile.Milano 2024, con una nuova sedia impilabile con braccioli in metallo e sgabello in due altezze. Minima nasce dall'idea di realizzare una famiglia di sedute accoglienti e robuste, dalle linee fluide ed energiche. Un progetto rassicurante nella sua visione precisa e puntuale, che si contraddistingue per i dettagli pesati e il profilo rigoroso. Minima is an all-wood seating collection that is enriched, on the occasion of the Salone del Mobile.Milano 2024, with a new stackable chair with metal armrests and stool in two heights. Minima was born from the idea of creating a family of cozy and strong chairs with fluid and energetic lines. A project reassuring in its precise and punctual vision, distinguished by its weighted details and rigorous profile.





MINIMA stackable dining chair 949, Cherry ash top.
 MINIMA stackable dining chair 949, Blulette ash top.
 MINIMA stackable dining chair 949, Olive green ash top.
 MINIMA stackable dining chair 949, White ash top.



MINIMA stackable dining chair 949, Blulette ash top.
 MINIMA stackable dining chair 949, White ash top.
 GRAPHIC circular dining table 955/TGC-OUT, Anthracite base, Moka ash wood top.



MINIMA stackable dining chair 949, Olive green ash wood frame.
MINIMA stackable dining armchair 949/P, Olive green ash wood frame, Black armrests.

NEWS 2024



NEWS 2024

MINIMA stackable dining chair 949/I, Olive green ash wood frame, Dolly Bosco Q2G.
MINIMA stackable dining armchair 949/PI, Olive green ash wood frame, Bronzed brass arm rests, Dolly Bosco Q2G.



NEWS 2024

MINIMA stackable dining chair 949/C, Carbon ash wood frame, Vienna straw seat.

MINIMA stackable dining armchair 949/PC, Carbon ash wood frame, Bronzed brass armrests, Vienna straw seat.



NEWS 2024

MINIMA barstool 949/AI, Bluette ash wood frame, Bronzed brass foot rest, Dolly Petrolio Q2F.
MINIMA barstool 949/AC, Carbon ash wood frame, Bronzed brass foot rest, Vienna straw seat.
MINIMA barstool 949/A, Biscuit ash wood frame Bronzed brass foot rest.

MINIMA

Design Mario Ferrarini

WOOD VERSION

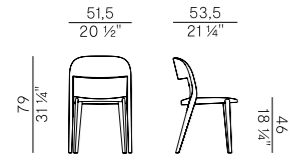

949  x4
sedia dining \ dining chair

VIENNA STRAW VERSION

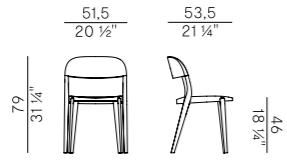

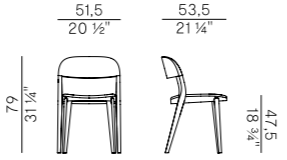

949/C  x4
sedia dining \ dining chair

UPHOLSTERED VERSION

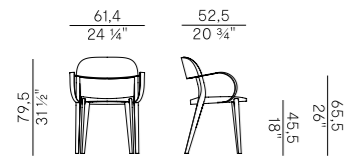

949/I  x4
sedia dining \ dining chair



949/P  x2
poltroncina dining \ dining armchair

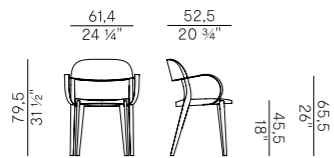

949/PC  x2
poltroncina dining \ dining armchair

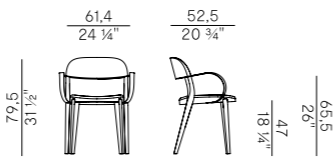

949/PI  x2
poltroncina dining \ dining armchair

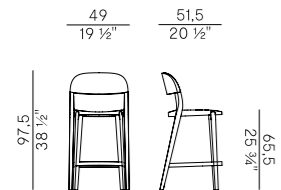

949/S
sgabello basso \ counter stool

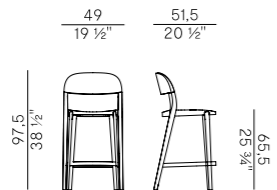

949/SC
sgabello basso \ counter stool

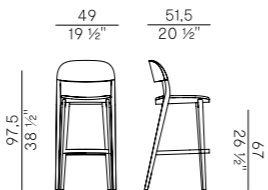

949/SI
sgabello basso \ counter stool

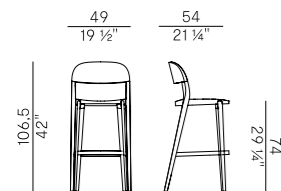

949/A
sgabello alto \ barstool

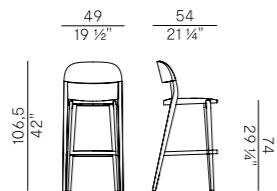

949/AC
sgabello alto \ barstool

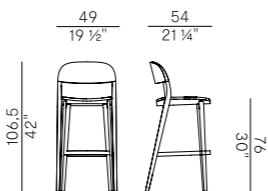

949/AI
sgabello alto \ barstool

FINITURE / FINISHES

STRUTTURA IN FRASSINO ASH FRAME



SG Beige \ Beige SC Biscotto \ Biscuit HJ Moka \ Moka HK Grigio plumbeo \ Dark grey HL Wengé \ Wengé HP Carbone \ Carbon SN Noce \ Walnut

STRUTTURA IN FRASSINO TINTO COLORI SPECIALI ASH WOOD FRAME STAINED SPECIAL COLORS

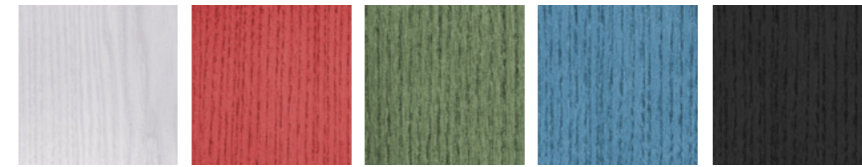

White Cherry Olive green Bluette Black

STRUTTURA IN NOCE CANALETTO CANALETTO WALNUT FRAME

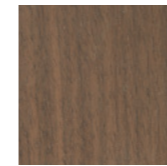

ES
Noce Canaletto \ Canaletto Walnut

SEDUTA IN PAGLIA DI VIENNA (949/C, 949/PC, 949/SC, 949/AC) VIENNA STRAW SEAT



Paglia di Vienna \ Vienna straw

BRACCIOLO E POGGIAPIEDI IN METALLO METAL ARMREST AND FOOTREST

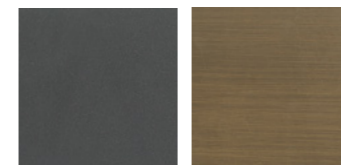

Antracite goffrato \ Anthracite embossed Ottone brunito \ Bronzed brass

SYN

*Rectangular dining table,
Circular dining table*

La collezione Syn indaga la relazione tra volumi multiformi che si incontrano, unendosi. Questa famiglia si declina in due tavoli da pranzo, con piano tondo e rettangolare, che vedono protagonista la base composta da un gioco di forme e materiali. La base rappresenta il cuore del progetto: due forme apparentemente lontane, un parallelepipedo e un cilindro, si intersecano tra loro creando un unico maestoso volume.

The Syn collection investigates the relationship between multiform volumes that combine to create a unique piece of furniture. This family is declined in two dining tables, with round and rectangular tops, whose protagonist is the base composed of an interplay of shapes and materials. The base represents the heart of the project: two seemingly distant shapes, a parallelepiped and a cylinder, intersect each other creating a single majestic volume.





SYN dining table 956/TC, White Carrara matt marble base,
Dark grey ash wood base, White Carrara matt marble top.

NEWS 2024





SYN

Design Mario Ferrarini

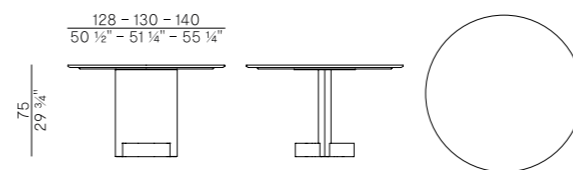

956/TC

tavolo \ table

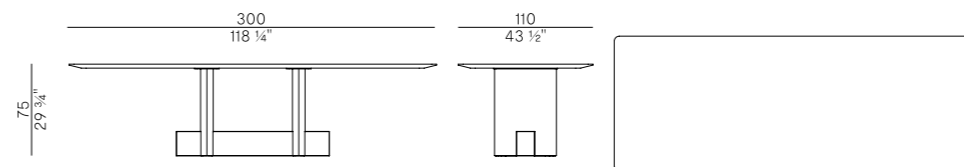

956/TR

tavolo \ table

FINITURE / FINISHES

BASE E PIANO IN FRASSINO
ASH BASE AND TOP

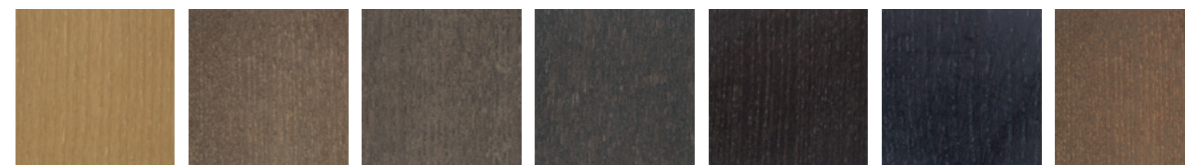

SG Beige \ Beige	SC Biscotto \ Biscuit	HJ Moka \ Moka	HK Grigio plumbeo \ Dark grey	HL Wengé \ Wengé	HP Carbone \ Carbon	SN Noce \ Walnut
----------------------------	---------------------------------	--------------------------	---	----------------------------	-------------------------------	----------------------------

BASE E PIANO IN MARMO
MARBLE BASE AND TOP

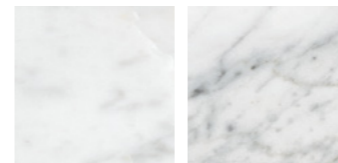

Bianco Carrara lucido \ Bianco Carrara opaco \
Glossy White Carrara \ Matt White Carrara

DETTAGLIO BASE IN MARMO
MARBLE BASE DETAIL

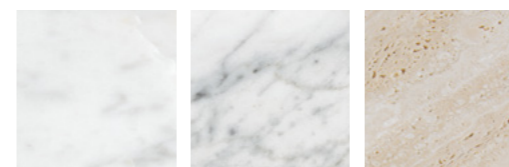

Bianco Carrara lucido \ Bianco Carrara opaco \ Travertino Romano \
Glossy White Carrara \ Matt White Carrara \ Travertino Romano

SYN dining table 956/TR, Travertino Romano marble base, Carbon ash wood base, Carbon ash wood top.

NEWS 2024

DOUBLE L GLAZE

Coffee tables, Side table

I tavolini Double L Glaze vengono proposti in una nuova e colorata variante interamente in vetro, disponibile in tre dimensioni e nelle colorazioni Honey, Cherry e Blueberry. Double L si configura come una collezione dall'estetica femminile e minimale, leggera ma caratterizzata da preziose lavorazioni e dettagli ricercati.

Double L Glaze coffee tables are presented in a new and colorful all-glass variant, available in three sizes and in Honey, Cherry and Blueberry colors. Double L is shaped as a collection with a feminine and minimalist aesthetic, light but characterized by precious workmanship and refined details.





DOUBLE L GLAZE

Design Chiara Andreatti

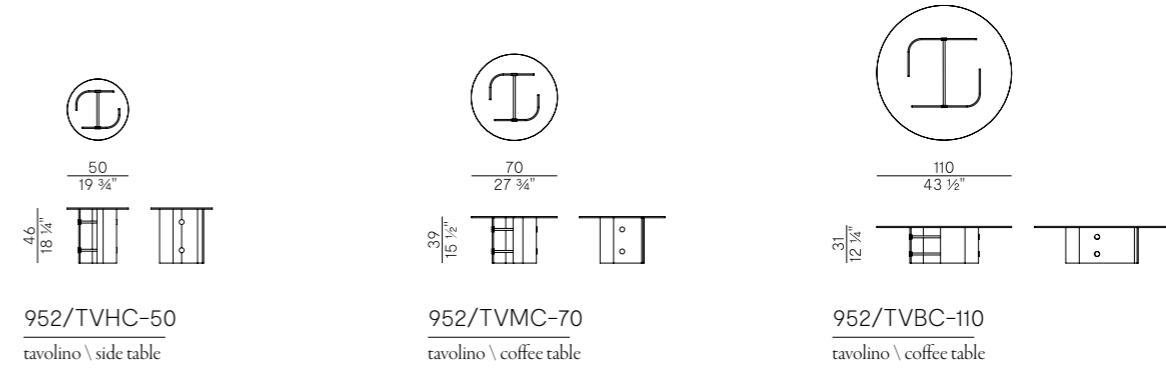

FINITURE / FINISHES

STRUTTURA IN VETRO TEMPERATO
TEMPERED GLASS FRAME



Honey Cherry Blueberry

RACCORDO TRA LE BASI
CONNECTION BETWEEN THE BASES



RAL 1032 RAL 4002 RAL 5010

NEWS 2024

DOUBLE L GLAZE side table 952/TVHC-50, Honey tempered glass base and top, RAL 1032 base connection.
DOUBLE L GLAZE coffee table 952/TVMC-70, Blueberry tempered glass base and top, RAL 4002 base connection.
DOUBLE L GLAZE coffee table 952/TVBC-110, Cherry tempered glass base and top, RAL 5010 base connection.

SEN

Cabinet

Famiglia di contenitori composta da madia e credenza, Sen si ispira al disegno delle tradizionali porte giapponesi in carta di riso. Il disegno del volume in frassino si stempera nella leggerezza visiva data dall'incrocio di griglie in massello di frassino, applicate ad ante scorrevoli in vetro che celano piani interni a diverse altezze. Le colorazioni del frassino si ampliano, in occasione del Salone del Mobile.Milano 2024, introducendo a catalogo una nuova e brillante finitura in color ciliegia.

Family of containers composed of sideboard and cabinet, Sen is inspired by the design of the traditional Japanese doors in rice paper. The design of the ash wood volume tones down thanks to the visual lightness created by the crossed grilles in solid ash wood, attached to sliding doors in tempered bronzed or transparent glass, hiding internal shelves at different heights. The colors of ash wood will be expanded, on the occasion of the Salone del Mobile.Milano 2024, introducing a bright new cherry-colored finish to the catalog.





SEN

Design Chiara Andreatti

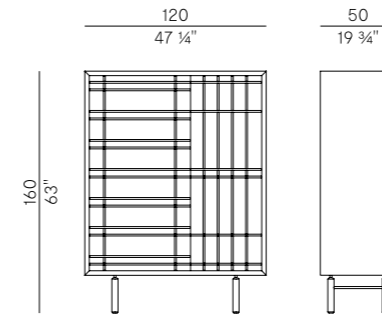

886/MA
credenza \ cabinet

FINITURE / FINISHES

STRUTTURA IN FRASSINO
ASH FRAME

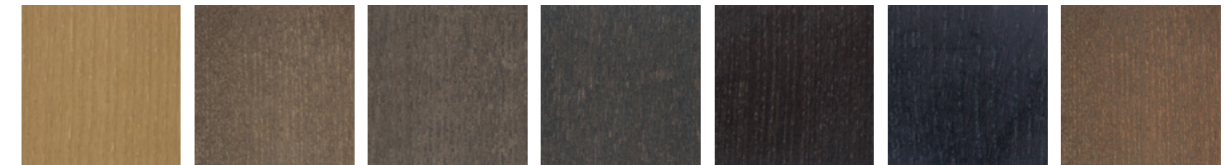

SG Beige \ Beige	SC Biscotto \ Biscuit	HJ Moka \ Moka	HK Grigio plumbeo \ Dark grey	HL Wengé \ Wengé	HP Carbone \ Carbon	SN Noce \ Walnut
----------------------------	---------------------------------	--------------------------	---	----------------------------	-------------------------------	----------------------------

PIANO IN VETRO TEMPERATO
TEMPERED GLASS TOP



Float trasparente \ Transparent float	Bronzato \ Bronzed
---------------------------------------	--------------------

STRUTTURA IN FRASSINO TINTO COLORI SPECIALI
ASH WOOD FRAME STAINED SPECIAL COLORS

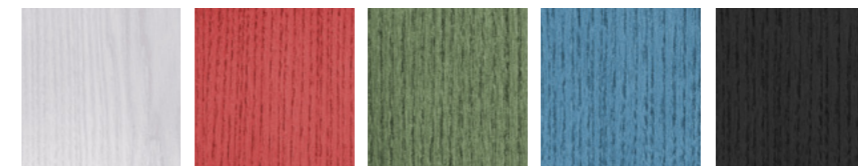

White	Cherry	Olive green	Bluette	Black
-------	--------	-------------	---------	-------

SEN cabinet 886/MA, Cherry ash wood frame,
Bronzed tempered glass doors.

NEW FINISH

HELVETICA

Dining chairs

Helvetica è un progetto di sedute nato dal dialogo tra la geometria e una sinuosità organica, il risultato del perfetto equilibrio tra decoro e essenzialità. Il progetto, realizzato in frassino e metallo con un'attenzione al mondo contract, è disponibile in due varianti che si differenziano per lo schienale, uno essenziale in legno massello curvato e l'altro che prevede l'aggiunta dell'imbottitura.

Helvetica is a seating design born from the dialogue between geometry and an organic sinuosity, the result of the perfect balance between decoration and essentiality. The design, made of ash wood and metal with a focus on the contract world, is available in two variants that differ in their backrests, one essential in curved solid wood and the other involving the addition of upholstery.



HELVETICA dining chairs 868/W - 868, Dark grey ash wood frame, Bronzed brass details, uph. Calla Pepe A8Q. NEWS 2024

HELVETICA

Design Park Associati

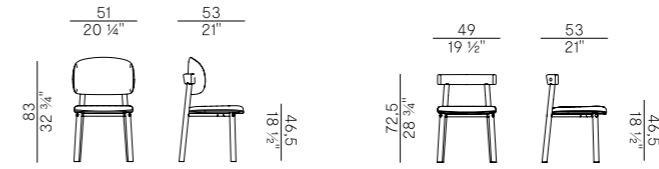

868
sedia dining \ dining chair

868/W
sedia dining \ dining chair

FINITURE / FINISHES

STRUTTURA IN FRASSINO
ASH FRAME

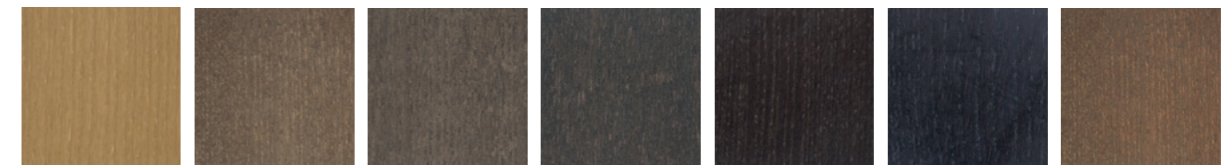

SG Beige \ Beige	SC Biscotto \ Biscuit	HJ Moka \ Moka	HK Grigio plumbeo \ Dark grey	HL Wengé \ Wengé	HP Carbone \ Carbon	SN Noce \ Walnut
---------------------	--------------------------	-------------------	-------------------------------------	---------------------	------------------------	---------------------

DETTAGLI OTTONE BRUNITO
BRONZED BRASS DETAILS

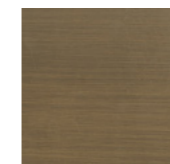

Ottone brunito \
Bronzed brass



—— Volumi di una raffinata semplicità danno vita ad un'architettura poetica, un linguaggio espressivo che dialoga con le emozioni e i sentimenti, in sintonia con lo scorrere del tempo. Una cifra stilistica dall'aspetto ricercato, fatta di tonalità tenui e linee morbide ed accoglienti.

Volumes of refined simplicity give life to a poetic architecture, an expressive language that dialogues with emotions and feelings, in harmony with the passage of time. A stylistic code with a refined look, which is made of delicate shades and soft and welcoming lines.

Architecture of emotions

Chapter III

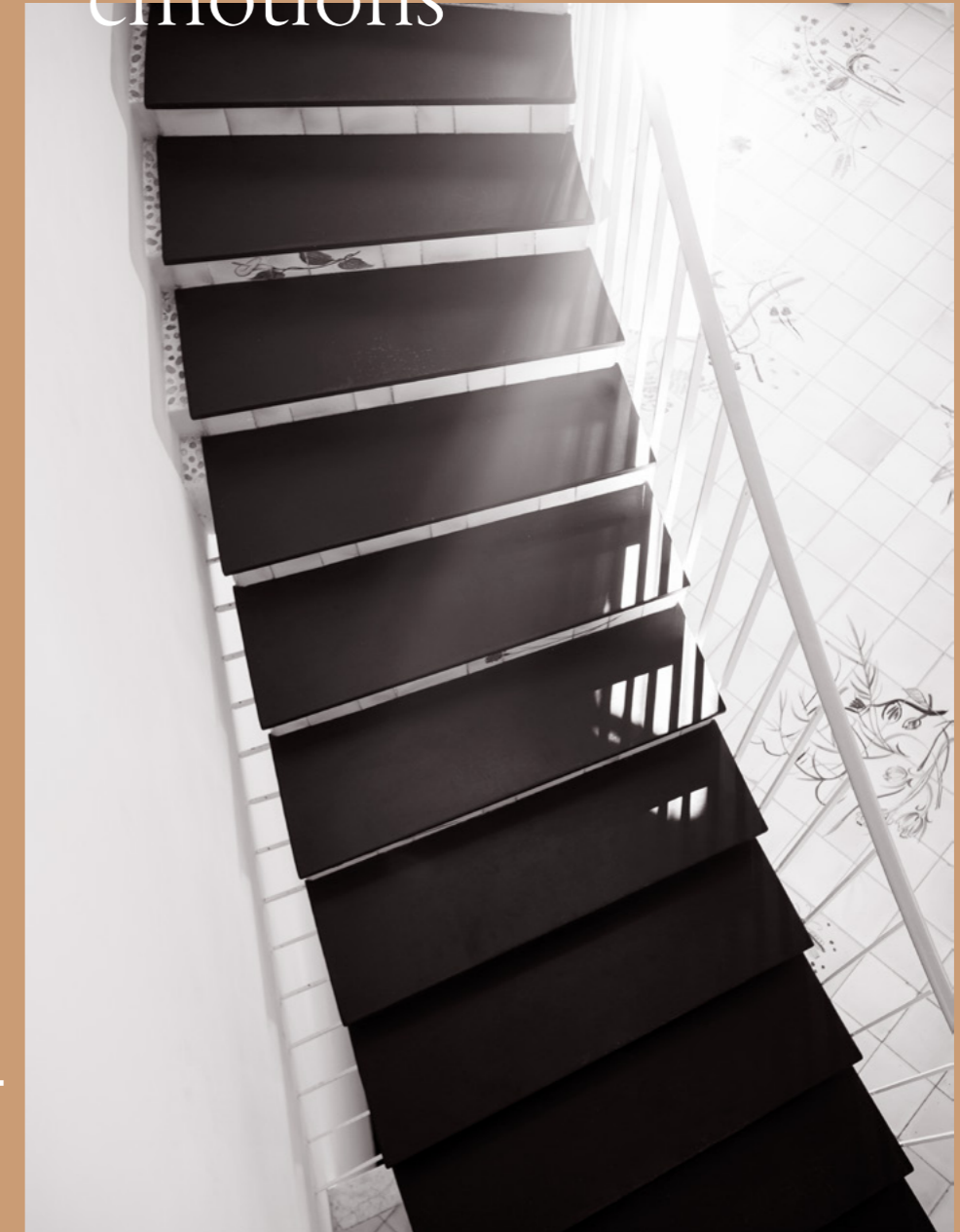

Velis dining armchair / Cut family / Trousse dining chair / Hishi coffee tables

VELIS CANE

Dining armchairs

Velis è un'ampia collezione di sedute pensata per rispondere alle diverse esigenze del vivere quotidiano. La linea raffinata ed essenziale e le proporzioni armoniosamente bilanciate la rendono adatta sia per progetti contract che per ambienti domestici. Lo schienale, proposto nella variante in legno o interamente imbottito, si arricchisce con una nuova finitura in canna che conferisce fascino e leggerezza alla silhouette.

Velis is a wide collection of seating designed to meet the different needs of everyday living. Its refined, essential lines and harmoniously balanced proportions make it suitable for both contract and domestic projects.

The backrest, offered in a wooden or fully upholstered version, is enriched with a new cane finish that lends charm and lightness to the silhouette.



VELIS CANE dining tub chairs 942/PACC - 942/PACI, NEWS 2024
Carbon ash wood frame, Natural cane backrest, uph. Dalí Pepe C6M.



VELIS CANE

Design Mario Ferrarini

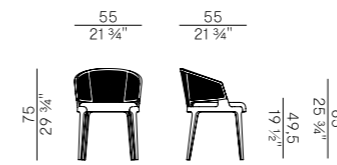

942/PACC

poltroncina pozzetto \ dining tub chair

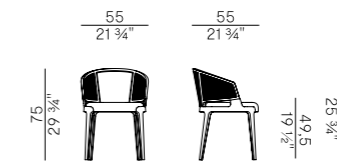

942/PACI

poltroncina pozzetto \ dining tub chair

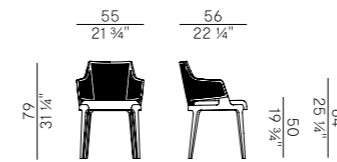

942/PBCC

poltroncina dining \ dining armchair

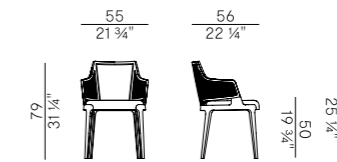

942/PBCI

poltroncina dining \ dining armchair

FINITURE / FINISHES

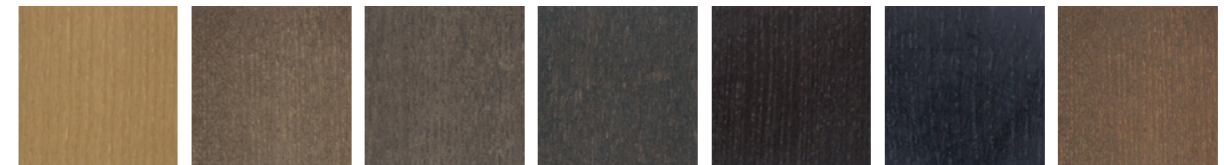
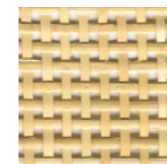
STRUTTURA IN FRASSINO
ASH FRAMESG
Beige \ BeigeSC
Biscotto \ BiscuitHJ
Moka \ MokaHK
Grigio plumbeo \
Dark greyHL
Wengé \ WengéHP
Carbone \ CarbonSN
Noce \ WalnutSCHIENALE IN PAGLIA NATURALE
NATURAL STRAW BACKRESTCanna naturale \
Natural cane

CUT

/Indoor

*Dining chair, Dining armchair,
Barstool, Counter stool*

La collezione Cut per indoor nasce dalla volontà di sviluppare una famiglia di sedute dalle forme ergonomiche e avvolgenti. Comfort ed eleganza si incontrano nel nuovo progetto di poltroncina e sgabello per interni, pensate per ampliare la proposta dining di Potocco destinata agli spazi più conviviali. Le gambe sottili in metallo goffrato sorreggono l'ampia e ospitale seduta a guscio interamente rivestita in tessuto sfoderabile. The Cut collection for indoor was born from the desire to develop a family of seats with ergonomic and embracing shapes. Comfort and elegance meet in the new design of armchair and stool for indoor, designed to expand Potocco's dining proposal designed for more convivial spaces. The slender, embossed metal legs support the wide, hospitable shell seat fully upholstered in removable fabric.



CUT dining chair and dining armchair 910 - 910/P, NEWS 2024
Aval metal frame, uph. Dolly Avorio cod. Q2A (removable fabric).



CUT barstool and counter stool 910/A - 910/S, NEWS 2024
Anthracite metal frame, uph. Cortina Senape cod. A9H (removable fabric).

CUT

Design Stephan Veit

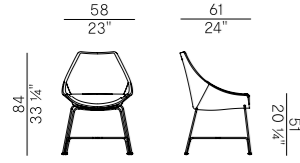

910

sedia dining \ dining chair

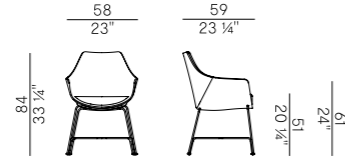

910/P

poltroncina dining \ dining armchair

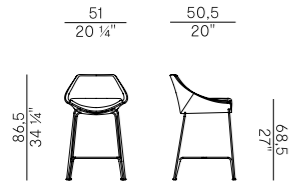

910/S

sgabello basso \ counterstool

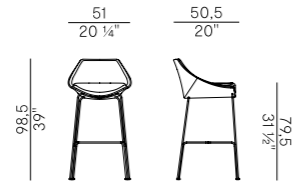

910/A

sgabello alto \ barstool

FINITURE / FINISHES

STRUTTURA IN METALLO VERNICIATO
LACQUERED METAL FRAME

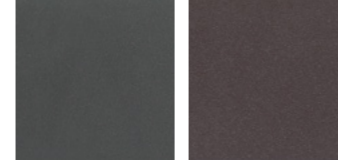

Antracite goffiato \
Anthracite embossed

Aval goffiato \
Aval embossed

CUT

/Outdoor

*Dining chair, Dining armchair, Barstool,
Counter stool, Rocking bergère*

Nella sua versione outdoor, Cut affianca alla bergère con poggiatesta la nuova poltroncina, lo sgabello, la sedia e la bergère a dondolo che ne ricalcano il profilo disegnato ed essenziale. La collezione prende forma da una struttura in tondino d'acciaio verniciato a polveri epossidiche, che disegna la silhouette armoniosa e longilinea di gambe e seduta, e da un guscio intrecciato a mano in fettuccia di gassa. L'intreccio accoglie il morbido cuscino di seduta a contrasto che enfatizza, grazie alle differenze cromatiche, i dettagli artigianali della lavorazione.

In its outdoor version, Cut complements the bergère with footrest with a new armchair, stool, chair and rocking bergère that follow its designed and essential profile. The collection takes shape from an epoxy powder-coated steel rod frame, which designs the harmonious, long-line silhouette of the legs and seat, and a hand-woven in beige "Gassa" ribbon. The weave accommodates the soft contrasting seat cushion, which emphasizes the handcrafted details of the workmanship through color differences.



CUT dining chair and armchair 910/R - 910/PR, Aval frame, "Gassa" beige Ribbon A7A, uph. Summer Red Blue B6M.





CUT barstool and counter stool 910/AR - 910/SR, Aval frame, "Gassa" beige Ribbon A7A, uph. Summer Red Blue B6M. NEWS 2024



CUT rocking bergère 910/PLR-Rocking, Aval frame, NEWS 2024
"Gassa" beige Ribbon A7A, Iroko wood sleds, uph. Soul Panna ZU.

CUT (outdoor)

Design Stephan Veit

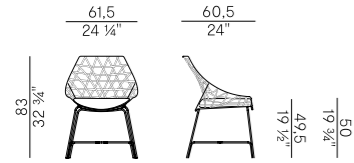

910/R

sedia dining \ dining chair

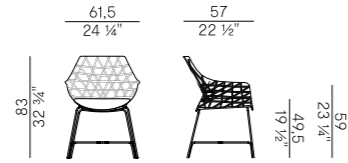

910/PR

poltroncina dining \ dining armchair

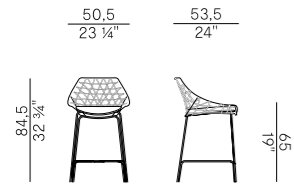

910/SR

sgabello basso \ counterstool

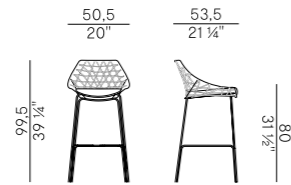

910/AR

sgabello alto \ barstool

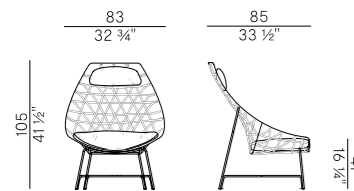

910/PLR

bergère \ bergère

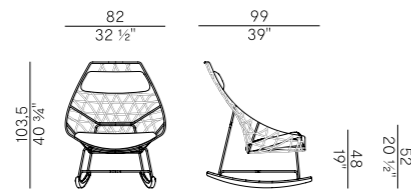

910/PLR-Rocking

rocking bergère \ rocking bergère

FINITURE / FINISHES

STRUTTURA IN METALLO VERNICIATO
LACQUERED METAL FRAME

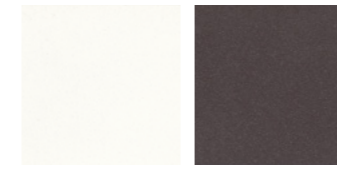

Bianco goffrato \
White embossed

Aval goffrato \
Aval embossed

INTRECCIO IN FETTUCCIA (910/R, 910/PR, 910/SR, 910/AR)
RIBBON WEAVING



A7A

Gassa beige \
Gassa beige

SLITTE (910/PLR-ROCKING)
SLEDS



EU

Iroko \ Iroko

TROUSSE

Stackable dining chair

La nuova sedia Trousse è un arredo misurato e versatile per la zona dining. Il progetto nasce con l'intento di creare una seduta con personalità ma capace, allo stesso tempo, di adattarsi a differenti ambientazioni grazie anche alla sua impilabilità, peculiarità che la rende versatile e pratica. Le gambe in massello di frassino e l'ampia seduta dai profili arrotondati contribuiscono a creare un arredo avvolgente con un'estetica contemporanea.

The new Trousse chair is a measured and versatile piece of furniture for the dining area. The design was created with the intention of crafting a seat with personality but capable, at the same time, of adapting to different settings due in part to its stackability, a peculiarity that makes it versatile and practical. Solid ash wood legs and a wide seat with rounded profiles contribute to the creation of an embracing piece of furniture with a contemporary aesthetic.





TROUSSE

Design Mario Ferrarini

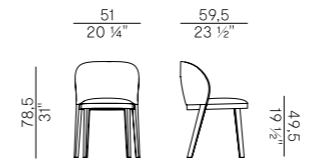
867
sedia dining \ dining chair

FINITURE / FINISHES

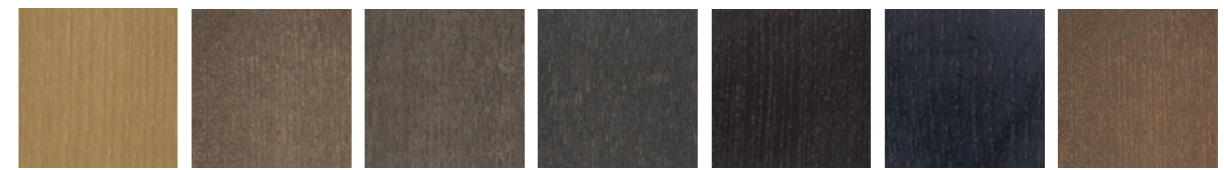
STRUTTURA IN FRASSINO
ASH FRAMESG
Beige \ BeigeSC
Biscotto \ BiscuitHJ
Moka \ MokaHK
Grigio plumbeo \
Dark greyHL
Wengé \ WengéHP
Carbone \ CarbonSN
Noce \ Walnut

HISHI

Indoor/Outdoor *Coffee tables*

La famiglia di tavolini Hishi è caratterizzata da una base in ceramica smaltata con un decoro a bassorilievo a maglia geometrica realizzato artigianalmente. La base, disponibile nelle tonalità cioccolato, pesca e grigio sabbia si arricchisce con due nuovi colori: una nuova tonalità in ceramica nera e una cromia rosa quarzo. Proposti in due diverse altezze, i tavolini sono disponibili con piano circolare o quadrato, in vetro bronzo temperato.

The Hishi family of side tables features a glazed ceramic base with a handcrafted geometric-patterned bas-relief decoration. The base, available in shades chocolate, peach and sand gray, is enriched with two new colors: a new black ceramic shade and a quartz pink hue. Offered in two different heights, the small tables are available with a round or square top, in bronze tempered glass.



HISHI

Design Chiara Andreotti

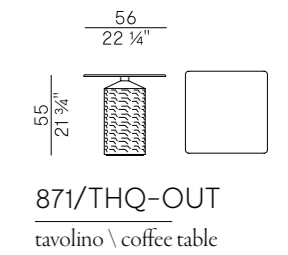
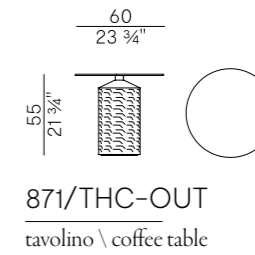
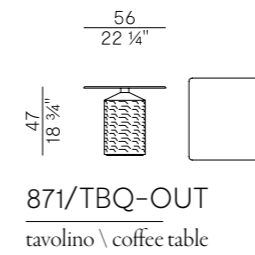
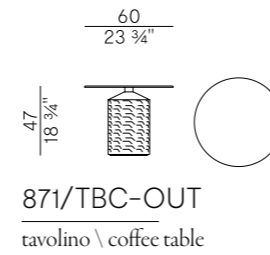
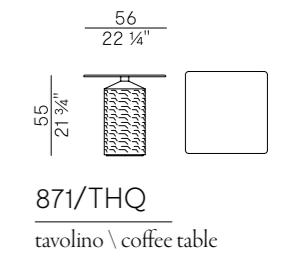
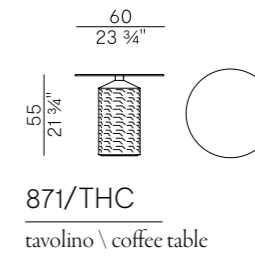
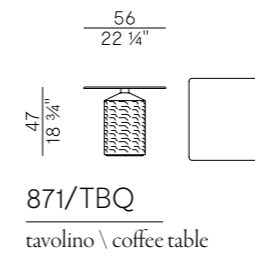
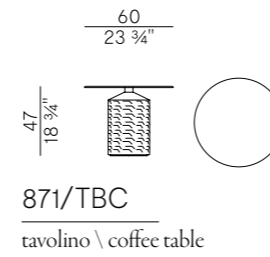

FINITURE / FINISHES

BASE IN CERAMICA
CERAMIC BASE



PIANO IN VETRO TEMPERATO
TEMPERED GLASS TOP



HISHI square side table 871/TBQ, Ceramic quartz pink base, Bronzed glass top. **NEW FINISH**
HISHI square side table 871/TBC, Ceramic black base, Bronzed glass top.

SOPHIE

Dining table

Il generoso tavolo da outdoor Sophie si compone di una base ottagonale in acciaio verniciato a polveri epossidiche rivestito in corda nautica color canapa oppure “Gassa” testa di moro, su cui si appoggia un piano in frassino waterproof, oppure in pietra naturale light grey. In occasione del Salone del Mobile.Milano 2024 il piano si tinge di una nuova finitura in ceramica colore burro.

The generous Sophie outdoor table consists of an octagonal base made of epoxy-powder-coated steel covered in hemp nautical rope or “Gassa” dark brown, on which rests a top made of waterproof ash wood, or natural light gray natural stone. On the occasion of the Salone del Mobile.Milano 2024, the top will be tinted with a new butter-colored ceramic finish.



SOPHIE

Design Chiara Andreatti

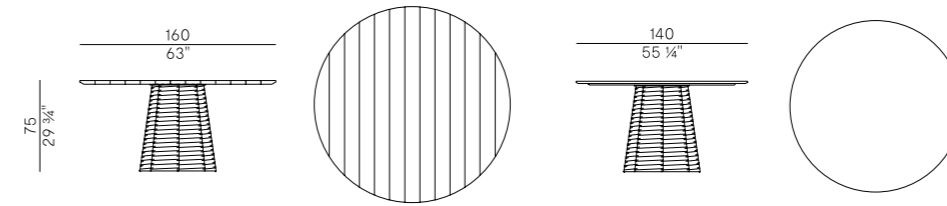

951/T

tavolo \ table

**FINITURE / FINISHES****INTRECCIO IN CORDA NAUTICA**
NAUTICAL ROPE WEAVING

F7F

Canapa \ Hemp

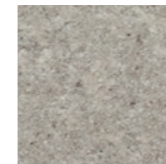
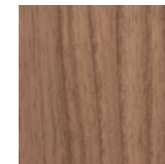

F8F

Gassa testa di moro \
Gassa dark brown**PIANO**
TOPC7C
Ceramica burro opaco \
Matt butter ceramicC8C
Pietra naturale light grey \
Light grey natural stoneS8S
Frassino waterproof \
Waterproof ash

Credits

POTOCCO NEWS 2024

Art direction

— *Chiara Andreatti Studio*

Project Coordination

— *Potocco Marketing Team*

Photos

— *Potocco Corporate Image Team*

Copy

— *CORA – Public Relations & Press Office*

Printing

— *Gruppo Logo*

Italy, April 2024



Potocco reserves the right to introduce any changes to its own models without prior notice. Color tones may vary from one dye lot to another.

© 2024 by Potocco S.p.A.
All rights reserved



The mark of responsible forestry

Richiedi i nostri prodotti certificati FSC®



www.potocco.it



POTOCCO

Via Indipendenza 4
33044 - Manzano, Udine - Italy
T. +39 0432 745111
© 2024 Potocco S.p.A.
info@potocco.it

Potocco USA
Hickory, NC 28602
United States of America
customerservice@potocco-usa.com

